

Owner's Guide

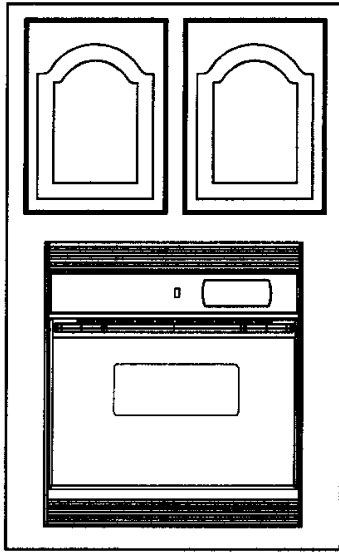

30-inch Gas Wall Oven with Self-Cleaning Oven

TABLE OF CONTENTS

IMPORTANT SAFETY INSTRUCTIONS	1-3	Oven Parts	15-18
WALL OVEN FEATURES	4	• Oven Vent	15
CLOCK, TIMER, OVEN CONTROL	5-6	• Cooling Fan	15
ABOUT YOUR WALL OVEN	7-18	• Oven Light	15
Pilotless Ignition	7	• Oven Door/Window	16
About The Oven	7	• Oven Racks	17
Oven Characteristics	7	• Oven Bottom	18
Oven Temperature Adjustment	7	CARE AND CLEANING CHART	19-20
General Information	8	SELF-CLEAN OVEN	21-22
Aluminum Foil Usage	8	SERVICE INFORMATION	23-26
Preheating	8	Troubleshooting Chart	23-25
How To Set The Oven	9-14	How To Remove Wall Oven For Cleaning And Servicing	26
• To Bake Or Roast	9	Electrical Connection	26
• To Timed Bake	10	WARRANTY	27
• Baking/Roasting Tips	11-12		
• To Broil	13-14		

INSTALLER Please leave this manual with this appliance.

CONSUMER To save you time, energy and money, read and keep this manual for future reference.

The model and serial numbers are found on the rating plate; see page 4 for location.

Model Number: _____

Serial Number: _____

Date of Purchase: _____

Please keep your sales receipt and/or your cancelled check as proof of purchase should warranty service be needed. Store these documents with this booklet.

FOR CUSTOMER ASSISTANCE CALL 1-800-688-1120

8113P160-60
(04-98-00)

74004140

1

IMPORTANT SAFETY INSTRUCTIONS

Read all instructions before using this appliance.

Thank You . . . for purchasing our cooking appliance. To help you obtain the maximum in cooking satisfaction, we offer these suggestions:

☞ Read this manual before using the appliance.

☞ Review all safety and caution instructions.

☞ Review the Troubleshooting Chart on pages 23 to 25 if service becomes necessary.

☞ Include the model and serial numbers of your appliance when requesting service.

- Proof of purchase such as sales receipt will be needed for warranty service.

☞ You can contact us at:

Maytag Appliances Sales Company
Attn: CAIRSM Center
P. O. Box 2370
Cleveland, TN 37320-2370
1-800-688-1120

In our continuing effort to improve the quality and performance of our cooking appliances, it may be necessary to make changes to the appliance without revising this manual.

WARNING: If the information in this manual is not followed exactly, a fire or explosion may result causing property damage, personal injury or death.

- Do not store or use gasoline or other flammable vapors and liquids in the vicinity of this or any other appliance.
- **WHAT TO DO IF YOU SMELL GAS:**
 - Do not try to light any appliance.
 - Do not touch any electrical switch.
 - Do not use any phone in your building.
 - Immediately call your gas supplier from a neighbor's phone. Follow the gas supplier's instructions.
 - If you cannot reach your gas supplier, call the fire department.
- Installation and service must be performed by a qualified installer, service agency or the gas supplier.

IMPORTANT SAFETY INSTRUCTIONS

2

IMPORTANT SAFETY INSTRUCTIONS

The following instructions are based on safety considerations and must be strictly followed to eliminate the potential risks of fire, electric shock, or personal injury.

Have your appliance installed and properly grounded by a qualified installer according to the installation instructions. Have the installer show you the location of the gas shut off valve and how to shut it off in an emergency.

Always disconnect power to appliance before servicing.

To ensure proper operation and avoid possible injury or damage to unit do not attempt to adjust, repair, service, or replace any part of your appliance unless it is specifically recommended in this book. All other servicing should be referred to a qualified installer or servicer.

TO PREVENT FIRE OR SMOKE DAMAGE

Be sure all packing materials are removed from the appliance before operating it.

Keep area around appliance clear and free from combustible materials, gasoline, and other flammable vapors and materials.

Many plastics are vulnerable to heat. Keep plastics away from parts of the appliance that may become warm or hot.

Many aerosol-type spray cans are **EXPLOSIVE** when exposed to heat and may be highly flammable. Avoid their use or storage near an appliance.

IN CASE OF FIRE

1. Turn off appliance.
2. Use dry chemical or foam-type extinguisher or baking soda to smother fire or flame. Never use water on a grease fire.
3. If fire is in the oven or broiler pan, smother by closing oven door.

CHILD SAFETY

NEVER leave children alone or unsupervised near the appliance when it is in use or is still hot. **NEVER** allow children to sit or stand on any part of the appliance.

Children must be taught that the appliance and utensils in it can be hot. Let hot utensils cool in a safe place, out of reach of small children. Children should be taught that an appliance is not a toy. Children should not be allowed to play with controls or other parts of the unit.



CAUTION: NEVER store items of interest to children in cabinets above an appliance. Children climbing on the appliance to reach items could be seriously injured.

ABOUT YOUR APPLIANCE

NEVER use appliance as a space heater to heat or warm a room to prevent potential hazard to the user and damage to the appliance. Also, do not use the oven as a storage area for food or cooking utensils.

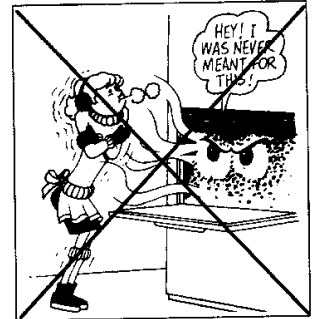

Do not obstruct the flow of combustion and ventilation air by blocking the oven vent or air intakes. Restriction of air flow to the burner prevents proper performance and increases carbon monoxide emission to unsafe levels.

Avoid touching oven vent area while oven is on and for several minutes after oven is turned off. Some parts of the vent and surrounding area become hot enough to cause burns. After oven is turned off, do not touch the oven vent or surrounding areas until they have had sufficient time to cool.

WARNING: NEVER use appliance door, as a step stool or seat as this may result in possible tipping of the appliance, damage to the appliance, and serious injury.

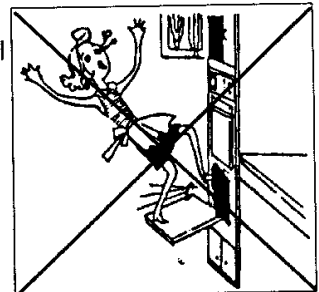

Do not touch a hot oven light bulb with a damp cloth as the bulb could break. Should the bulb break, disconnect power to the appliance before removing bulb to avoid electrical shock.

COOKING SAFETY

NEVER heat an unopened container in the oven. Pressure build-up may cause container to burst resulting in serious personal injury or damage to the appliance.

Use dry, sturdy pot holders. Damp pot holders may cause burns from steam. Dish towels or other substitutes should never be used as pot holders because they can trail across hot burners and ignite or get caught on appliance parts.

NEVER wear garments made of flammable material or loose fitting or long hanging-sleeved apparel while cooking. Clothing may ignite or catch utensil handles.

Always place oven racks in the desired positions while oven is cool. Slide oven rack out to add or remove food, using dry sturdy pot holders. Always avoid reaching into the oven to add or remove food. If a rack must be moved while hot, use a dry pot holder. Always turn the oven off at the end of cooking.

Use care when opening the oven door. Let hot air or steam escape before removing or replacing food.

PREPARED FOOD WARNING: Follow food manufacturer's instructions. If a plastic frozen food container and/or its cover distorts, warps, or is otherwise damaged during cooking, immediately discard the food and its container. The food could be contaminated.

UTENSIL SAFETY

Follow the manufacturer's directions when using oven cooking bags.

Only certain types of glass, glass/ceramic, ceramic, or glazed utensils are suitable for cooktop or oven usage without breaking due to the sudden change in temperature.

This appliance has been tested for safe performance using conventional cookware. Do not use any devices or accessories that are not specifically recommended in this manual. Do not use add-on oven convection systems. The use of devices or accessories that are not expressly recommended in this manual can create serious safety hazards, result in performance problems, and reduce the life of the components of the appliance.

CLEANING SAFETY

Turn off all controls and wait for appliance parts to cool before touching or cleaning them.

Clean appliance with caution. Use care to avoid steam burns if a wet sponge or cloth is used to wipe spills on a hot surface. Some cleaners can produce noxious fumes if applied to a hot surface.

SELF-CLEAN OVEN

Clean only parts listed in this manual. Do not clean door gasket. The door gasket is essential for a good seal. Care should be taken not to rub, damage, or move the gasket. Do not use oven cleaners of any kind in or around any part of the self-clean oven.

Before self-cleaning the oven, remove broiler pan, oven racks, and other utensils, and wipe off excessive spillovers to prevent excessive smoke or flare ups. **CAUTION:** Do not leave food or cooking utensils, etc. in the oven during the self-clean cycle.

IMPORTANT SAFETY NOTICE AND WARNING

The California Safe Drinking Water and Toxic Enforcement Act of 1986 (Proposition 65) requires the Governor of California to publish a list of substances known to the State of California to cause cancer or reproductive harm, and requires businesses to warn customers of potential exposures to such substances.

Users of this appliance are hereby warned that the burning of gas can result in low-level exposure to some of the listed substances, including benzene, formaldehyde and soot, due primarily to the incomplete combustion of natural gas or liquid petroleum (LP) fuels. Properly adjusted burners will minimize incomplete combustion. Exposure to these substances can also be minimized by properly venting the burners to the outdoors.

SAVE THESE INSTRUCTIONS

WALL OVEN FEATURES

4

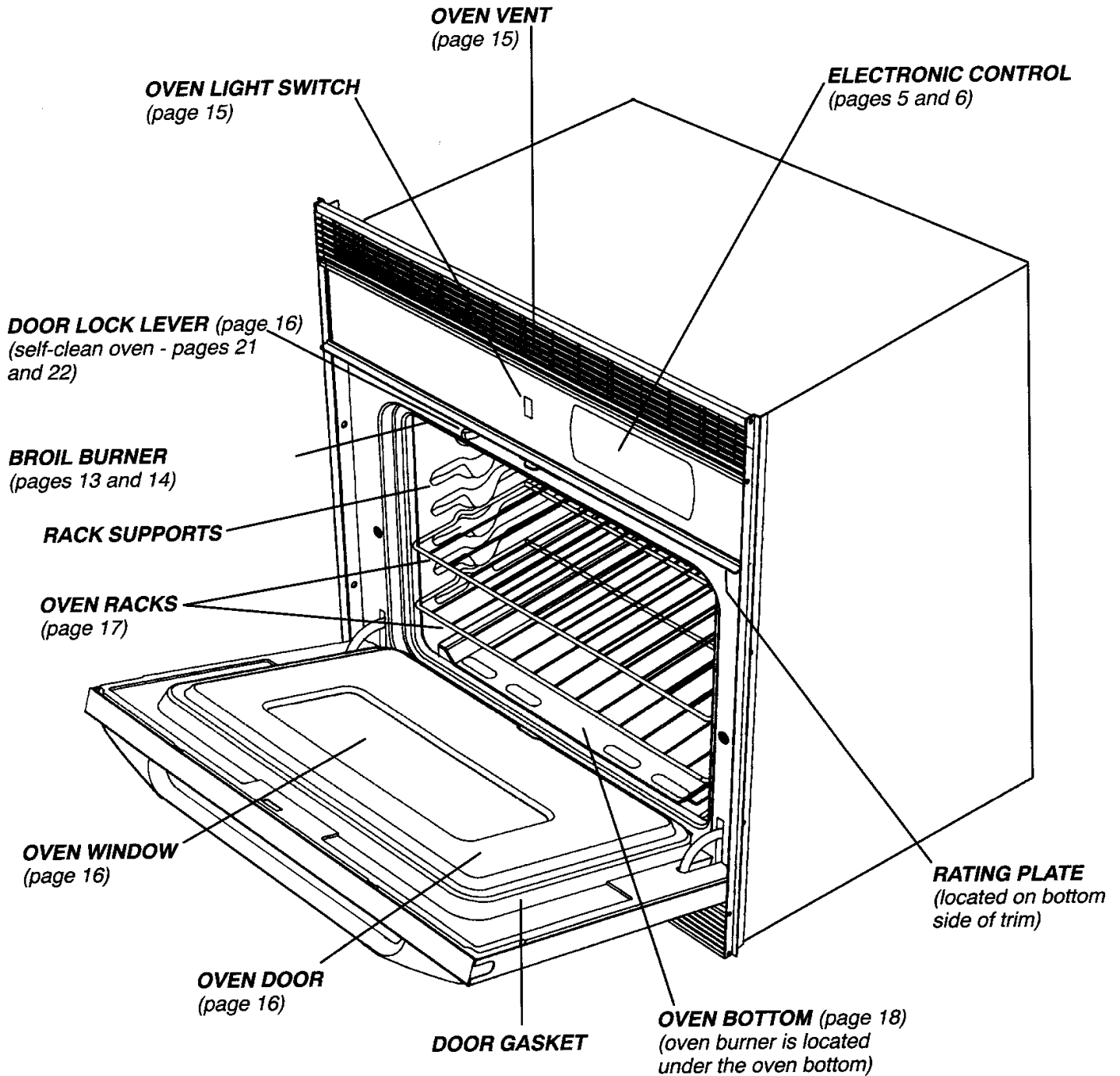

Press this pad to cancel all operations except the TIMER. The time of day will reappear in the display.

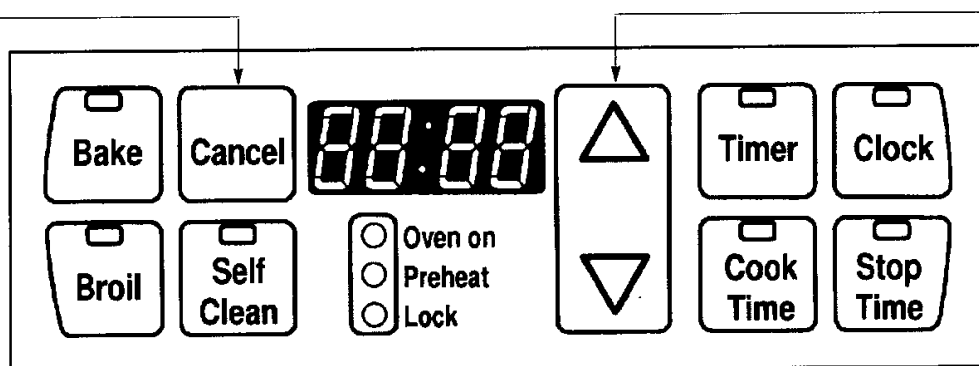

Press or press and hold these pads to enter time, oven temperature or to select HI or LO broil.

ABOUT THE FUNCTION PADS

- A beep will sound when these pads are pressed: BAKE, BROIL, SELF-CLEAN, TIMER, CLOCK, COOK TIME, STOP TIME, and CANCEL pads.
- All function pads except the CANCEL pad feature an indicator light.

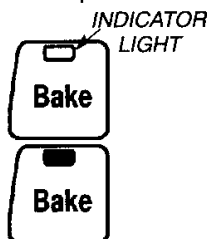

When the BAKE or BROIL pad is pressed, the indicator light will turn on to let you know that the oven is set for this operation.

Indicator lights on SELF-CLEAN, TIMER, CLOCK, COOK TIME and STOP TIME pads will **flash** when the pad is pressed. These indicator lights will stop flashing but will remain lit once the function starts.

- If an indicator light on a function pad is lit and you set a second operation:
 - Either the control will not accept the operation or
 - The indicator light on the first pad will "dim" slightly and the indicator light on the pad you just pressed will be "full on." This lets you know that you have set the control for two operations.

For example: If you set the oven to bake at 350°F and then set a timing operation, the indicator light on the BAKE pad will "dim" and the indicator light on the TIMER pad will be "full on."

The display will show the operation for the pad with the "full on" indicator light. Press the function pad with the "dim" indicator light to recall that operation.

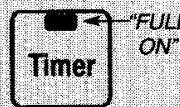
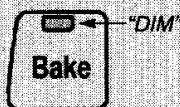

HOW TO SET CLOCK

- Press CLOCK pad.
- Press or press and hold ▲ or ▼ pad until correct time of day appears in display.

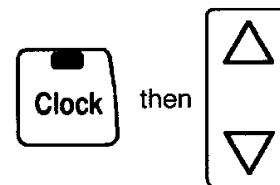

- Display will flash when power is supplied to unit.
- Clock time cannot be changed if oven is set for timed bake or delayed clean operation. Cancel the operation before setting the clock.
- If timer is in use, press CLOCK pad **once** to recall the time of day or **twice** to reset the time of day.

To recall time of day when another function is displayed, press CLOCK pad.

CLOCK DISPLAY DISABLE FEATURE

If you prefer that the time of day is not displayed:

- Press and hold **both** CLOCK and CANCEL pads for **several seconds**.
- Repeat step 1 to reactivate clock feature.

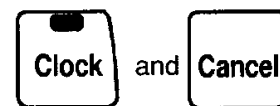

- When clock display is disabled, press CLOCK pad to recall time of day for 4 seconds. Display will then blank.
- If a power failure occurs when the clock has been disabled, the display remains blank and will not flash when power is restored.

CLOCK, TIMER, OVEN CONTROL

6

HOW TO SET TIMER

1. Press TIMER pad.
2. Press or press and hold ▲ or ▼ pad until correct time appears in display.

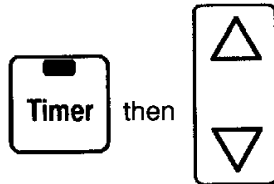

- The timer feature does not operate the oven.
- The timer can be set from 1 minute [0:01] up to 9 hours and 50 minutes [9:50].
- The timer will start automatically.
- The TIMER indicator on the TIMER pad will light whenever the timer is in use.
- One long beep and "End" will be briefly displayed to signal the end of the timer operation.

To cancel timer: Press and hold TIMER pad for 3 seconds. Time of day will reappear in the display.

12 HOUR ENERGY SAVER FEATURE

The 12 Hour Energy Saver feature automatically turns off the oven if it was accidentally left on after 12 hours.

To deactivate this feature so the oven will NOT turn off automatically at the end of 12 hours:

1. Press and hold CLOCK pad for 3 seconds.
2. Press ▲ or ▼ pad until 8:88 appears in the display.
 - Current time of day will reappear in the display after 4 seconds.
3. Repeat steps 1 and 2 to reactivate the 12 Hour Energy Saver feature.
 - 12:00 will appear in display to indicate the Energy Saver feature is restored.

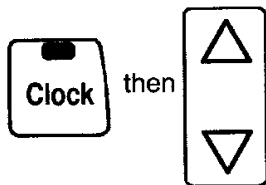

"END OF TIMED COOK" BEEPS

You have a choice of three "end of timed cook" reminder beeps for the Automatic Oven Timer feature.

- **Option 1:** Four beeps then one beep every 30 seconds for the **next 5 minutes** or until CANCEL pad is pressed. (Default option.)
- **Option 2:** Four beeps. There are no other beeps.
- **Option 3:** Four beeps then one beep every minute for the **next 12 hours** or until CANCEL pad is pressed.

How to select the desired option:

1. Press and hold **both** COOK TIME and CLOCK pads for 3 seconds.

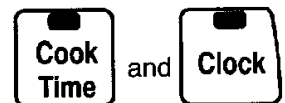

- A single beep will sound.
- Display will show current option.

2. Press ▲ or ▼ pad to select the option number you wish.



- The current time of day will reappear in the display after 4 seconds.

OVEN CONTROL LOCK-OUT FEATURE

The Control Lock-Out feature prevents the oven from being turned on. This is especially helpful when cleaning the control panel.

To activate:

1. Press and hold **both** STOP TIME and CANCEL pads for 3 seconds.

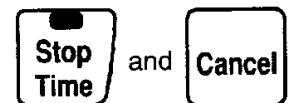

2. "OFF" will appear in display when this feature is activated.
 - Only the clock and timer functions will operate when Control Lock-Out feature is activated.
3. Repeat step 1 to deactivate this feature.

PILOTLESS IGNITION

- Be sure oven control is set in the OFF position prior to supplying gas to the appliance.
- Your appliance features pilotless ignition. A glo bar will light the oven burner.
- With this type of ignition system, the oven will not operate during a power failure or if the oven is disconnected from the wall outlet.
- **No attempt should be made to operate oven during a power failure.**

ABOUT THE OVEN

- The oven temperature is maintained by cycling the oven burner on and off.
- After the oven temperature has been set, there will be about a 45 second delay before the burner ignites. This is normal and no gas escapes during this delay.
- During the clean cycle, and some extended oven cooking operations, you may hear a "popping" sound when the burner cycles off. This is a normal operating sound of the burner.

OVEN CHARACTERISTICS

- Because each oven has its own personal baking characteristics, do not expect that your new oven will perform exactly like your previous oven.
- You may find that the cooking times, oven temperatures, and cooking results differ somewhat from your previous range.
- Allow a period of adjustment.
- If you have questions concerning baking results, please refer to pages 8, 11 and 12 for additional information.

OVEN TEMPERATURE ADJUSTMENT

You can adjust the oven temperature if you feel the temperature is too hot or too cool.

To adjust the oven temperature:

1. Press BAKE pad.
2. Press ▲ pad until 550° is displayed.
3. Press and hold BAKE pad for 3 seconds until 00° appears in display.
4. Press or press and hold the ▲ or ▼ pad to select the temperature change you wish.

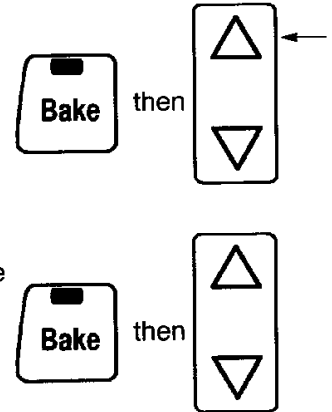

- The oven temperature can be increased or decreased by 5° to 35°F.
- If the oven temperature was previously adjusted, the change will be displayed.

For example: If the oven temperature was reduced by 15°, the display will show - 15°.

5. Time of day will automatically reappear in display.

It is not necessary to readjust the oven temperature if there is a power failure or interruption.

Broiling and cleaning temperatures cannot be adjusted.

GENERAL INFORMATION

- Do not lock oven door during a cooking operation.
 - If the door is locked the LOCK indicator will light and the operation will be canceled.



Unlock the door then reset the operation.

- If oven temperature is above 400°F, the internal locking mechanism will engage and the door can not be unlocked until the oven has cooled.
- If you press BAKE or BROIL pad and do not set an oven temperature or broil setting within 30 seconds:
 - The program will automatically cancel.
 - The time of day will reappear in the display.
- To change oven temperature or broil setting during cooking:

- If temperature is displayed, press ▲ or ▼ pad to select the new temperature.
- If another function is displayed, press BAKE or BROIL pad then press ▲ or ▼ pad to select new temperature.



ALUMINUM FOIL USAGE

- Do not cover an entire oven rack or oven bottom with aluminum foil. This will reduce heat circulation, result in poor baking and may damage the oven bottom.
- A small piece of foil may be used to catch spillovers. Place it on a lower rack several inches below the food.

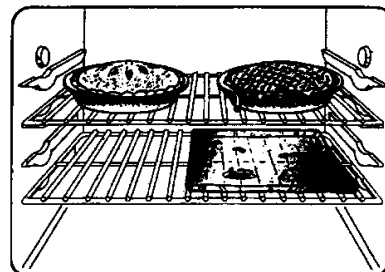

- Do not cover the broiler insert with aluminum foil. This prevents fat from draining into the pan below and increases flare-ups and smoke. However, the broiler pan may be lined with foil for easier clean-up.

PREHEATING

- Preheating is necessary for baking.
- It is not necessary to preheat for roasting.
- To preheat, set the oven to the desired temperature and allow about 8 to 15 minutes for the oven to preheat. A single beep will indicate that the oven is preheated.
- Selecting a temperature higher than desired will NOT preheat the oven any faster, and may have a negative effect on baking results.

HOW TO SET OVEN TO BAKE OR ROAST

1. Press BAKE pad.

- BAKE indicator on the BAKE pad will light.
- 000 will light in display.

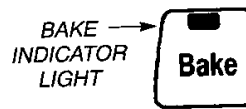

2. Press or press and hold ▲ or ▼ pad to select oven temperature.

- 350° will light when either pad is pressed.
- Oven temperature can be set from 170° to 550°.

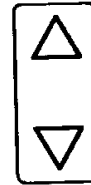

3. There will be a 4 second delay before the oven turns on. When the oven turns on:

- OVEN ON indicator will light.
- PREHEAT indicator will light.
- The preselected temperature will remain in display.



4. Allow 8 to 15 minutes for the oven to preheat.

- A single beep will indicate that the oven has preheated.
- The OVEN ON indicator will remain lit.
- The PREHEAT indicator will turn off.



5. Place food in the oven.

NOTE: The oven temperature can be changed at any time. If the temperature is changed, the PREHEAT indicator will turn back on until the new temperature is reached. A beep will signal that the new temperature has been reached.

6. Check cooking progress at the minimum cooking time. Cook longer if needed.

NOTE: See pages 11 and 12 for additional information on baking and roasting.

7. Press CANCEL pad and remove food from the oven.

- The BAKE indicator on the BAKE pad will turn off.
- The OVEN ON indicator will turn off.
- Time of day will reappear in display.

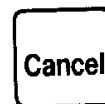

NOTE: If you forget to turn off the oven, it will automatically turn off at the end of 12 hours. If you wish to deactivate this energy saving feature, see page 6.

AUTOMATIC OVEN TIMER CONTROL



- Highly perishable foods such as dairy products, pork, poultry, seafood or stuffing are not recommended for a delayed cooking operation.
- Baking is not recommended because preheating is required.

The clock must be functioning and correctly set.

- **Immediate start:** Follow steps 1-4 and 6-8. Oven turns on immediately and automatically turn off at a preset time.
- **Delayed start:** Follow steps 1-8. Delays the start of cooking or cleaning and automatically turns off at a preset time.

Cook time can only be set for up to 11 hours and 59 minutes (11:59).

HOW TO SET TIMED COOK OPERATION

1. Press COOK TIME pad.
 - COOK TIME indicator on the COOK TIME pad will flash.
 - 0:00 will light in display.
2. Press or press and hold ▲ or ▼ pad to enter cooking time.

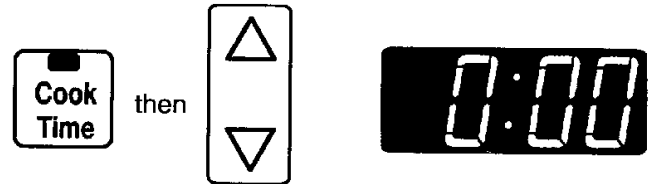

3. Press BAKE pad.
 - BAKE indicator on BAKE pad will light.
 - 000 will light in display.
4. Press or press and hold ▲ or ▼ pad to enter oven temperature.

NOTE: Beeps will sound and 000 will flash in display if the BAKE pad is not pressed within 4 seconds.

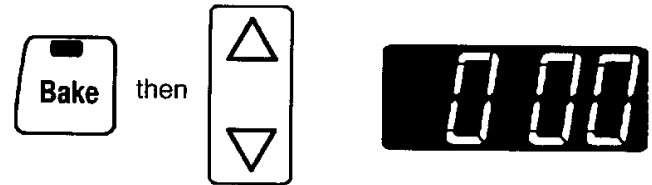

5. **IF YOU WISH TO DELAY THE START OF COOKING** (if not, skip to #6):
 - a. Press STOP TIME pad.
 - STOP TIME indicator on STOP TIME pad will flash.
 - b. Press or press and hold ▲ or ▼ pad to enter time of day you wish oven to turn off.
 - c. Press CLOCK pad.
 - Time of day will reappear in display.

NOTE: If you wish to delay the start of cooking follow all 8 steps. If you wish to begin cooking immediately, follow all steps except step 5 – skip step 5.

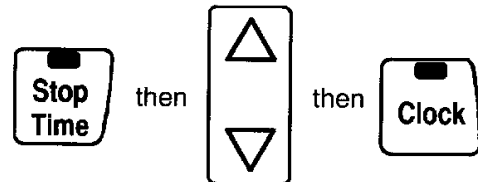

6. When the oven turns on, the OVEN ON indicator will light. The oven temperature will appear in the display. Press the COOK TIME pad to recall the remaining cook time.

NOTE: It is not necessary to set a start time. Control will determine when to turn the oven on based on the cook time you set.

7. Oven will automatically turn off. Four beeps will sound and “End” will light in display. A beep will sound every 30 seconds for the next 5 minutes.

NOTE: See page 6 if you wish to change the end of cooking reminder beeps.

8. Press CANCEL pad and beeps will stop. Remove food from oven.



BAKING TIPS

Use a **reliable recipe** and accurately measure fresh ingredients. **Carefully follow directions** for oven temperature and cooking time. Preheat oven if recommended.

Use the **correct rack position**. Baking results may be affected if the wrong rack position is used.

- Top browning may be darker if food is located toward the top of the oven.
- Bottom browning may be darker if food is located toward the bottom of the oven.

Bakeware material plays an important part in baking results. Always use the type and size of pan called for in the recipe. Cooking times or cooking results may be affected if the wrong size is used.

- **Shiny metal pan** reflects heat away from the food, produces lighter browning and a softer crust. Use shiny pans for baking cakes or cookies.
- **Dark metal pan** or **a pan with an anodized (dull) bottom** absorbs heat, produces darker browning and a crisper crust. Use this type of pan for pies, pie crusts or bread.
- For optimum baking results, bake cookies and biscuits on a **flat** cookie sheet. If the pan has sides, such as a jelly roll pan, browning may not be even.
- If using **oven-proof glassware**, or **dark pans such as Baker's Secret** reduce the oven temperature by 25°F except when baking pies or bread. Use the same baking time as called for in the recipe.
- If using insulated bakeware, expect cooking times to increase slightly. It is not necessary to adjust the oven temperature.

Check the cooking progress at the minimum time recommended in the recipe. If necessary, continue checking at intervals until the food is done. If the oven door is opened too frequently, heat will escape from the oven; this can affect baking results and wastes energy.

If you add additional ingredients or alter the recipe, expect cooking times to increase or decrease slightly.

ROASTING TIPS

Roasting is the method for cooking large, tender cuts of meat uncovered, without adding moisture. Most meats are roasted at 325°F. It is not necessary to preheat the oven.

- For best results use tender cuts of meat weighing 3-lbs. or more.
- Some good choices are: Beef rib, ribeye, top round, high quality tip and rump roast, pork loin roast, leg of lamb, veal shoulder roast and cured or smoked hams.
- Place the meat fat-side-up on a rack in a shallow roasting pan. Placing the meat on a rack holds it out of the drippings, thus allowing better heat circulation for even cooking. As the fat on top of the roast melts, the meat is basted naturally, eliminating the need for additional basting.
- The cooking time is determined by the weight of the meat and the desired doneness.
- For more accurate results, use a meat thermometer. Insert it so the tip is in the center of the thickest part of the meat. It should not touch fat or bone.
- Remove the meat from the oven when the thermometer registers the desired doneness.

NOTE: For more information about food safety, call USDA's Meat & Poultry Hotline at 1-800-535-4555.

For cooking information, write to the National Cattle-men's Beef Association, 444 North Michigan Avenue, Chicago, Illinois 60611, or call 1-800-368-3138.

COMMON BAKING PROBLEMS AND WHY THEY HAPPEN

PROBLEM	POSSIBLE CAUSES
<i>Cakes are uneven.</i>	<ul style="list-style-type: none"> • Pans too close or touching each other or oven walls. • Batter uneven in pans. • Temperature set too low or baking time too short. • Oven not level. • Undermixing. • Too much liquid.
<i>Cake high in middle.</i>	<ul style="list-style-type: none"> • Temperature set too high. • Baking time too long. • Overmixing. • Too much flour. • Pans touching each other or oven walls. • Incorrect rack position.
<i>Cake falls.</i>	<ul style="list-style-type: none"> • Too much shortening or sugar. • Too much or too little liquid. • Temperature set too low. • Old or too little baking powder. • Pan too small. • Oven door opened frequently. • Added incorrect type of oil to cake mix. • Added additional ingredients to cake mix or recipe.
<i>Cakes, cookies, biscuits don't brown evenly.</i>	<ul style="list-style-type: none"> • Incorrect rack position. • Oven door not closed properly. • Door gasket not sealing properly or properly attached to door. • Incorrect use of aluminum foil. • Oven not preheated. • Pans darkened, dented or warped. <p>For optimum results, bake on one rack. If baking cakes on two racks, place pans toward the front of the oven on the upper rack and toward the back of the oven on the lower rack.</p>
<i>Cakes, cookies, biscuits too brown on bottom.</i>	<ul style="list-style-type: none"> • Oven not preheated. • Pans touching each other or oven walls. • Incorrect rack position. • Incorrect use of aluminum foil. • Placed 2 cookie sheets on one rack. • Used glass, dark, stained, warped or dull finish metal pans. (Use a shiny cookie sheet.) <p>Follow cookware manufacturer's instructions for oven temperature. Glassware and dark cookware such as Ecco's Baker's Secret may require lowering the oven temperature by 25°F.</p>
<i>Cakes don't brown on top.</i>	<ul style="list-style-type: none"> • Incorrect rack position. • Temperature set too low. • Overmixing. • Too much liquid. • Pan size too large or too little batter in pan. • Oven door opened too often.
<i>Excessive shrinkage.</i>	<ul style="list-style-type: none"> • Too little leavening. • Overmixing. • Pan too large. • Temperature set too high. • Baking time too long. • Pans too close to each other or oven walls.
<i>Uneven texture.</i>	<ul style="list-style-type: none"> • Too much liquid. • Undermixing. • Temperature set too low. • Baking time too short.
<i>Cakes have tunnels.</i>	<ul style="list-style-type: none"> • Not enough shortening. • Too much baking powder. • Overmixing or at too high a speed. • Temperature set too high.
<i>Cake not done in middle.</i>	<ul style="list-style-type: none"> • Temperature set too high. • Pan too small. • Baking time too short. <p>If additional ingredients were added to mix or recipe, expect cooking time to increase.</p>
<i>Pie crust edges too brown.</i>	<ul style="list-style-type: none"> • Temperature set too high. • Pans touching each other or oven walls. • Edges of crust too thin; shield with foil.
<i>Pies don't brown on bottom.</i>	<ul style="list-style-type: none"> • Used shiny metal pans. • Temperature set too low. • Incorrect rack position. • Some frozen pies should be placed on a cookie sheet, check package directions.
<i>Pies have soaked crust.</i>	<ul style="list-style-type: none"> • Temperature too low at start of baking. • Filling too juicy. • Used shiny metal pans.

HOW TO SET OVEN TO BROIL

1. Press BROIL pad.

- BROIL indicator on the BROIL pad will light.
- 000 will light in display.

BROIL
INDICATOR
LIGHT



2. Press the ▲ pad to select HI (high) broil or the ▼ pad to select LO (low) broil.

- Select HI broil for normal broiling.
- Select LO broil for low temperature broiling of longer cooking foods such as poultry.



← HI

← LO



3. There will be an 8 second delay before the oven turns on. When the oven turns on:

- The OVEN ON indicator will light.



4. Place food in the oven. The oven door is closed for broiling.

NOTE: See page 14 for broiling instructions and broiling chart.

5. Turn meat once about half way through cooking.

6. Press CANCEL pad. Remove food and broiler pan from the oven.

- The OVEN ON indicator will turn off.
- The BROIL indicator on the BROIL pad will turn off.
- Time of day will reappear in display.



BROILING TIPS

Broiling is used for tender cuts of meat or marinated meats, poultry, fish and some fruits and vegetables. The food is placed directly under the broil burner.

Cooking time is determined by the desired degree of doneness and the distance between the food and the element.

- For best results, steaks and chops should be at least 3/4-inch thick. Thinner cuts should be pan broiled.
- Before broiling, trim excess fat to prevent excessive spattering or smoking. Cut slashes in the outer edges of the fat to prevent curling during cooking.
- Season meat after cooking. Salt tends to draw juices out of the meat and delay browning.
- Use a broiler pan with an insert designed to drain excess liquid and fat away from the cooking surface. This is to prevent spatters and smoke.
- For a brown exterior and rare interior, meat should be close to the broil burner. For well-done meat, place the broiler pan farther from the burner.
- Increasing the distance between the meat and the broil burner will help reduce spattering and smoking.
- Select Lo Broil for longer cooking foods such as chicken pieces.
- Foods that require turning should be turned only once during broiling. Turn after half the recommended cooking time.

BROILING CHART			
TYPE OF MEAT	RACK POSITION*	DONENESS	TOTAL TIME (MINUTES)**
BACON	#4	Well Done	6 to 10
BEEF STEAKS 1-inch thick	#4 #4	Medium Well Done	15 to 20 20 to 25
CHICKEN Pieces	#3 or #4	Well Done	LO BROIL 30 to 45
FISH Fillets	#4	Flaky	8 to 12
Steaks, 1-inch thick	#4	Flaky	12 to 15
GROUND BEEF PATTIES 3/4-inch thick	#4	Well Done	15 to 20
HAM SLICE, precooked 1/2-inch thick	#4	Warm	8 to 12
PORK CHOPS 1-inch thick	#4	Well Done	20 to 25

* The top rack position is position #5.

** Broiling times are approximate and may vary depending on the meat.

OVEN VENT

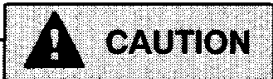

When oven is in use, the area near the oven vent opening may feel warm or hot to the touch.

The oven vent is located above the control panel.

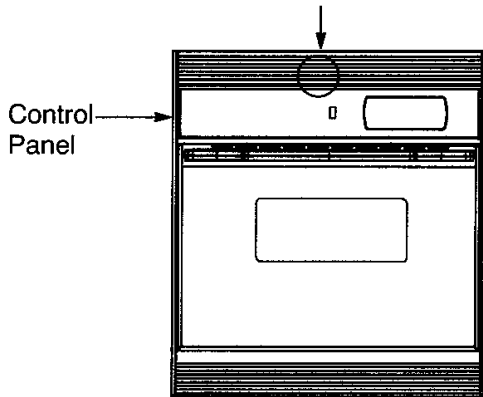

When the oven is in use, this area may feel warm or hot to the touch.

To prevent baking problems, do not block the vent opening.

COOLING FAN

A cooling fan will automatically turn on, if needed, to help keep the interior component parts cool during some cooking and all cleaning operations.

The fan will automatically turn off when the oven has cooled.

OVEN LIGHT

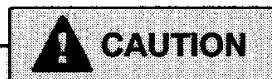

- Disconnect power to wall oven by tripping circuit breaker or removing fuse before replacing light bulb.
- Be sure bulb is cool before touching or replacing bulb.
- Use a dry potholder to prevent possible harm to hands when replacing bulb.
- Do not touch hot bulb with a damp cloth as this may cause the bulb to break.

To turn on the oven light: Push in rocker switch located on the control panel.

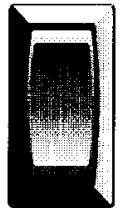

To replace oven light bulb:

1. Disconnect power to wall oven.
2. Hold bulb cover in place then slide wire retainer off cover. **NOTE:** Bulb cover will fall if not held in place while removing wire retainer.
3. Remove bulb cover.
4. Remove light bulb and replace with a 40 watt appliance bulb.
5. Replace bulb cover and secure with wire retainer.
6. Reconnect power to wall oven. Reset clock.

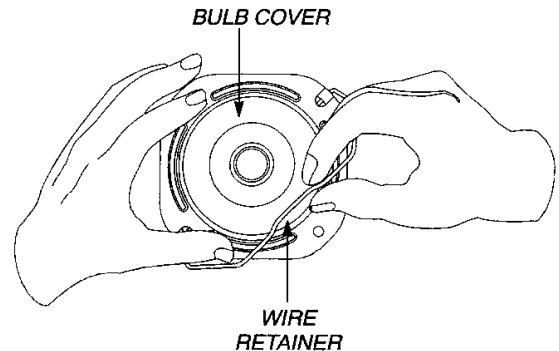

CAUTION

- **WARNING: NEVER** place excessive weight on or stand on an open oven door. This could cause the range to tip over, break the door, or injure the user.
- **NEVER** place fingers between hinge and front oven frame. Hinge arms are spring mounted. If accidentally hit, the hinge will slam shut against oven frame and could injure your fingers.

OVEN DOOR

When baking, be sure oven door is completely closed. Baking results will be affected if door is not closed.

NOTE: When oven is new, the oven door may feel “spongy” when you close the door. This is normal and will become less “spongy” with use.

To remove lift-off oven door:

1. When cool, open oven door to the stop position (opened about 4-inches).
2. Grasp door at each side.
3. Lift up evenly until door clears hinge arms. Do not use door handle to lift door.

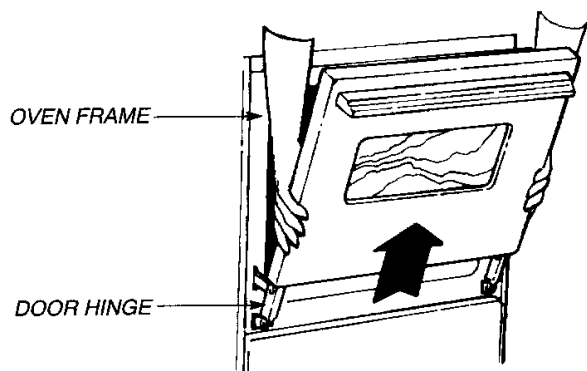

To place oven door back on wall oven:

1. Grasp door at each side.
2. Align slots in door with hinge arms on range.
3. Slide door down onto hinge arms until door is completely seated on hinges. Then push down on top corners of door to completely seat door on hinges.

Door is not completely seated if one side is higher or if door appears to be crooked.

Do not attempt to open or close door or operate oven until door is properly replaced.

OVEN WINDOW

To protect the oven door window:

1. Do not use abrasive cleaning agents such as steel wool scouring pads or powdered cleansers as they may scratch the glass.
2. Do not hit the glass with pots, pans, furniture, toys, or other objects.
3. Do not close the oven door until the oven racks are in place.

Scratching, hitting, jarring or stressing the glass may weaken its structure causing an increased risk of breakage at a later date.

DOOR LOCK LEVER

The door lock lever is used to lock the oven door during a self-clean operation. To lock door, move the lever to the right. This is the locked position for the clean cycle.

Do not move the lock lever to the right or locked position when baking. If the door is accidentally locked:

- The cooking operation will be canceled.
- If oven temperature is above 400°F, the door will not unlock until the oven has cooled.
- Allow oven to cool then unlock and open door. (Place a fan in front of oven to speed cooling.)

OVEN RACKS



Do not attempt to change the rack position when the oven is hot.

The oven rack is designed with a safety lock-stop position. This prevents the rack from accidentally coming completely out of the oven when pulling the rack out to add or remove food.

To remove:

1. When rack is cool, pull rack straight out until it stops at the lock-stop position.

NOTE: If it is necessary to change rack position when rack is hot, use potholders to protect hands.

2. Tilt the front end of the rack up.
3. Continue pulling rack out of oven.

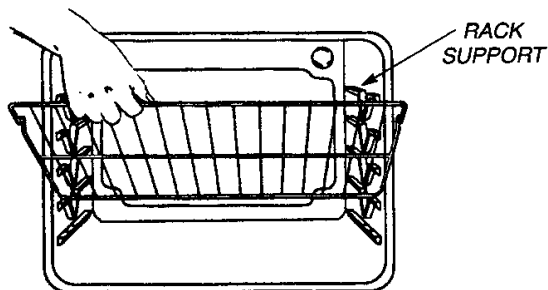
**To replace:**

1. Place rack on the rack supports in oven.
2. Tilt the front end of the rack up slightly.
3. Slide rack back until it clears the lock-stop position.
4. Lower front of rack and slide rack straight back into oven.
5. **IMPORTANT:** Pull rack out to the lock-stop position to be sure rack is correctly replaced.
6. If properly installed, rack will not come out of oven unless the front edge is lifted up.
7. Push rack back into oven and close oven door.

RACK POSITIONS

- For optimum results, air must circulate freely within the oven and around the food. To help ensure this, place food in the center of the oven. Allow two inches between the edge of the pan(s) and the oven walls.
- Use one rack for optimum baking results of cakes, cookies or biscuits.

Position the rack so the food is in the center of the oven. Use either rack position 2 or 3.

- If cooking on two racks, stagger the food to ensure proper air flow.

- If cooking on two racks, use rack positions 2 and 4 for cakes and rack positions 1 and 4 or 2 and 5 when using cookie sheets.

Never place two cookie sheets on one rack.

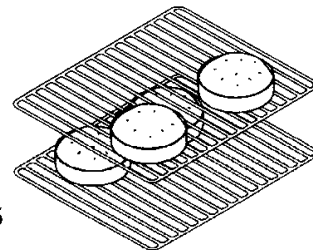

- If roasting a large turkey, place the turkey on rack 1 and the side dishes on rack 5.

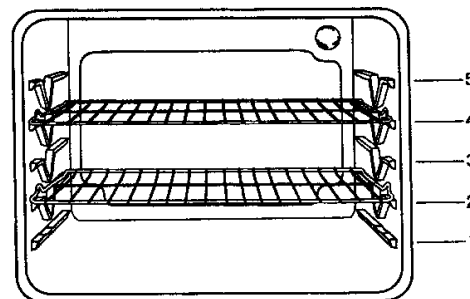

RACK 5 (highest position): Used for toasting bread, or for two-rack baking.

RACK 4: Used for most broiling and two-rack baking.

RACK 3: Used for most baked goods on a cookie sheet or jelly roll pan, or for frozen convenience foods.

RACK 2: Used for roasting small cuts of meat, large casseroles, baking loaves of bread, cakes (in either tube, bundt, or layer pans) or two-rack baking.

RACK 1: Used for roasting large cuts of meat and large poultry, pies, souffles, or angel food cake, or for two-rack baking.

OVEN BOTTOM

Protect oven bottom against excessive spillovers especially acid or sugary spillovers as they may discolor the porcelain.

To protect oven bottom:

- Use the correct size cooking utensil to avoid boilovers.
- Place a piece of aluminum foil that is slightly larger than the pan on the oven rack directly below the pan if boilovers are expected.
- Never place cookware or aluminum foil directly on the oven bottom.

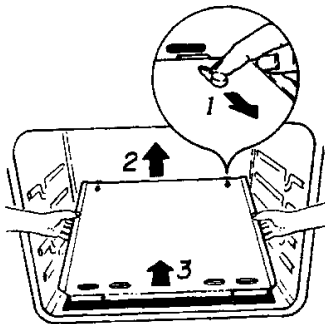

To remove:

1. When cool, remove the oven racks. Slide the two catches, located at each rear corner of the oven bottom, toward the front of the oven.
2. Lift the rear edge of the oven bottom slightly.
3. Then, slide it back until the front edge of the oven bottom clears the oven front frame. Remove oven bottom from oven.

To replace:

1. Fit the front edge of the oven bottom into the oven front frame.
2. Lower the rear of the oven bottom.
3. Slide the two catches back to lock the oven bottom into place.

**CAUTION**

- Be sure appliance is off and all parts are cool before handling or cleaning. This is to avoid damage and possible burns.
- If a part is removed, be sure it is correctly replaced.
- **To prevent staining or discoloration, clean appliance after each use.**

CLEANING CHART

PARTS	CLEANING AGENTS	CLEANING PROCEDURES
Broiler pan and insert	<ul style="list-style-type: none"> • Soap and water • Plastic or soap filled scouring pad • Dishwasher 	<p>Never cover insert with aluminum foil as this prevents the fat from draining to pan below.</p> <ol style="list-style-type: none"> 1. Remove from oven after use. Cool then pour off grease. 2. Place soapy cloth over insert and pan; let soak to loosen soil. 3. Wash in warm soapy water. Use soap filled scouring pad to remove stubborn soil. 4. Broiler pan and insert can be cleaned in the dishwasher.
Enamel, painted	<ul style="list-style-type: none"> • Soap and water • Mild liquid cleaner • Glass cleaner 	<p>NOTE: Use dry towel or cloth to wipe up spills, especially acid (milk, lemon juice, fruit, mustard, tomato sauce) or sugary spills. Surface may discolor or dull if soil is not immediately removed. This is especially important for white surfaces.</p> <ol style="list-style-type: none"> 1. When cool, wash with warm soapy water, rinse and dry. Never wipe a warm or hot surface with a damp cloth as this may damage the surface and may cause a steam burn. 2. For stubborn soil, use mildly abrasive cleaning agents such as baking soda paste or Bon Ami. 3. Do not use abrasive, caustic or harsh cleaning agents such as steel wool pads or oven cleaners. These products will scratch or permanently damage the surface.
Glass <ul style="list-style-type: none"> • Oven door • Oven window 	<ul style="list-style-type: none"> • Soap and water • Glass cleaner • Paste of baking soda and water • Cooktop cleaner - conditioner 	<p>To prevent staining of the oven window, avoid using excessive amounts of water which may seep under or behind glass.</p> <ol style="list-style-type: none"> 1. Wash with soap and water. Remove stubborn soil with paste of baking soda and water. Rinse with clear water and dry. 2. Do not use abrasive materials such as scouring pads, steel wool or powdered cleaning agents. They will damage glass.
Metal finishes such as brushed aluminum, or chrome <ul style="list-style-type: none"> • Oven door • Trim parts 	<ul style="list-style-type: none"> • Soap and water • Glass cleaner • Plastic or non-abrasive pad or sponge 	<ol style="list-style-type: none"> 1. Wash with soap and water or a glass cleaner and a soft cloth. 2. To prevent scratching or dulling of the finish, do not use mildly abrasive, abrasive, or harsh cleaners, or caustic cleaners such as oven cleaners. 3. To clean brushed aluminum: Use only soap and water or a soft cloth and glass cleaner to prevent scratching or dulling of the finish. 4. To clean brushed chrome cooktop or door: <ul style="list-style-type: none"> • Use a paste of baking soda and water and a soft cloth. • Rub with the grain to prevent scratching, dulling or streaking of the finish. • Use a soft cloth and mineral oil to restore luster or to remove fingerprints or smudges. • Clean with an automotive chrome cleaner or polisher.

(continued next page)

CARE AND CLEANING CHART

20

PARTS	CLEANING AGENTS	CLEANING PROCEDURES
Oven bottom	<ul style="list-style-type: none"> • Soap and water • Paste of baking soda and water • Non-abrasive plastic pad 	<p>Protect oven bottom against acid spills (milk, cheese, tomato, lemon juice, etc.) or sugary spills (pie filling) as they may pit or discolor the oven bottom.</p> <p>To make cleaning easier, protect the oven bottom by (1) using large enough cookware to prevent boilovers; (2) place a piece of aluminum foil, that is slightly larger than the cookware, on the lower rack. NEVER place foil directly on the oven bottom.</p> <p>For easier cleaning, oven bottom can be removed and cleaned at the sink. Do not soak or immerse oven bottom in water or place under running water. See Porcelain enamel below for additional information.</p>
Oven racks	<ul style="list-style-type: none"> • Soap and water • Plastic scouring pad • Cleansing powders • Soap-filled scouring pad 	<ol style="list-style-type: none"> 1. Clean with soapy water. 2. Remove stubborn soil with cleansing powder or soap-filled scouring pad. Rinse and dry. <p>Racks will permanently discolor and may not slide smoothly if left in the oven during a self-clean operation. If this occurs, wipe the rack and embossed rack supports with a small amount of vegetable oil to restore ease of movement, then wipe off excess oil.</p>
Plastic finishes • Door handles • Trim	<ul style="list-style-type: none"> • Soap and water • Non-abrasive plastic pad or sponge • Glass cleaner 	<p>NOTE: To prevent staining or discoloration, wipe up fat, grease or acid (tomato, lemon, vinegar, milk, fruit juice, marinade) immediately with a dry paper towel or cloth.</p> <ol style="list-style-type: none"> 1. When cool, clean with soap and water, rinse, and dry. 2. Use a glass cleaner and a soft cloth. <p>NOTE: Never use oven cleaners, abrasive or caustic liquid or powdered cleansers on plastic finishes. These cleaning agents will scratch or mar finish.</p>
Porcelain enamel • Oven cavity • Oven bottom	<ul style="list-style-type: none"> • Soap and water • Paste of baking soda and water • Non-abrasive plastic pad or sponge 	<p>Porcelain enamel is glass fused on metal and may crack or chip with misuse. It is acid resistant, not acid proof. All spillovers, especially acid or sugar spillovers, should be wiped up immediately with a dry cloth. See page 21 for instructions on the self-clean oven.</p> <p>About the oven bottom:</p> <ol style="list-style-type: none"> 1. Protect oven bottom against acid spills (milk, cheese, tomato, lemon juice, etc.) or sugary spills (pie filling) as they may pit or discolor the oven bottom. 2. To make cleaning easier, protect the oven bottom by (1) using large enough cookware to prevent boilovers; (2) place a piece of aluminum foil, that is slightly larger than the cookware, on the lower rack. NEVER place foil directly on the oven bottom. 3. For easier cleaning, oven bottom can be removed and cleaned at the sink. Do not soak or immerse oven bottom in water or place under running water.

ABOUT CLEANING PRODUCTS

- Read the manufacturer's instructions to be sure the cleaner can be safely used on this appliance.
- Carefully follow manufacturer's directions.
- Test a small inconspicuous area to see if cleaning product is safe. This is important for porcelain enamel, highly polished or shiny metal or plastic surfaces, and painted surfaces.

Glass Cleaners – Cinch, Glass Plus, Windex.

Dishwashing Liquid Detergents – Dawn, Dove, Ivory.

Mild Liquid Spray Cleaners – Fantastik, Formula 409.

Non-Abrasive Cleaners – Paste of baking soda and water.

Mildly Abrasive Powder or Liquid All Purpose Cleansers – Ajax, Barkeepers Friend, Bon Ami, Cameo, Comet, Soft Scrub, Elco Cleaner-conditioner.

Non-Abrasive or Scratchless Plastic or Nylon Scouring Pads or Sponges – Chore Boy Plastic Cleaning Puff, Scrungie Scrub Sponges, or Scotch-Brite No Scratch, Cookware or Kitchen Sponge.

Abrasive Scouring Pads – S.O.S., Brillo Steel Wool Soap, Scotch-Brite Pads.

(Brand names for the above cleaning products are registered trademarks of the respective manufacturers.)

**CAUTION**

- It is normal for parts of the range to become hot during a clean cycle.
- Avoid touching cooktop, door, window, or oven vent area during a clean cycle.
- To prevent damage to oven door, do not attempt to unlock the door when the LOCK indicator is displayed.
- It is normal for excessive flare-ups and smoking to occur during cleaning if the oven is heavily soiled.

BEFORE CLEAN CYCLE

- Turn off oven light before cleaning as the light may burn out during a clean cycle.
- Remove pans, broiler pan, and oven racks.

NOTE: Racks may discolor and not slide easily after cleaning.

- Clean oven frame and door frame. These areas are not exposed to cleaning temperatures; soil may bake on during clean cycle.
- To prevent damage, do not clean gasket located on oven door. Gasket seals in heat during the clean cycle.
- To prevent excessive smoke, flare-ups or flaming, wipe up excess grease or spillovers from oven bottom.
- Porcelain is acid resistant, not acid proof and may discolor during the clean cycle. To prevent or reduce discoloration, wipe up sugar or acid spills (lemon, milk, barbecue sauce, cheese).

DURING CLEAN CYCLE

- As oven heats, the LOCK indicator will light in the display. At this point, the door can not be unlocked and opened.
- To prevent damage to door or lock lever, do not force door open when the LOCK indicator is displayed.
- Some smoke and odor may be detected the first few times the oven is cleaned. This is normal and will lessen in time.
- Smoke may occur if oven is heavily soiled or if broiler pan was left in oven.
- As oven heats, you may hear sounds of metal parts expanding and contracting. This is normal and will not damage oven.

AFTER CLEAN CYCLE

- The LOCK indicator will turn off about one hour after clean cycle ends. The door can be unlocked and opened. Use care as oven may still be hot.
- A gray powdery ash may remain on the oven bottom or walls. This is normal. Use a damp cloth to remove ash.
- If soil remains, the clean cycle may not have been long enough.
- Wipe oven racks with a small amount of vegetable oil if racks do not slide easily after clean cycle.
- Clean around oven vent opening if there is a deposit from the fumes vented during cleaning.
- Fine lines may appear in the porcelain. This is normal and results from the heating and cooling of the finish. This will not affect oven performance.
- A white discoloration may appear after cleaning if acid soils (milk, tomato, lemon, etc.) or sugary soils were not wiped up before the clean cycle. This discoloration is normal and will not affect the performance of the clean cycle.

CLEANING TIPS

- Clean oven regularly rather than allowing soil to build-up.
- Do not use oven cleaners in, on, or around any part of the range as they will damage the finish or parts.

SELF-CLEAN OVEN

22

HOW TO SET OVEN FOR A SELF-CLEAN CYCLE

1. Move door lock lever to locked position.



2. Press SELF-CLEAN pad.

- CLEAN indicator on the SELF-CLEAN pad will flash.
- 3:00 will light in display.
- If door is not locked, "dr" will appear in display. Lock door.



then

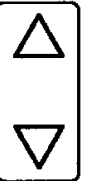

3. Press ▲ or ▼ pad to select clean time.

- You can select from 2 up to 4 hours.
- Oven will automatically clean for 3 hours. Or,
 - Select 2 hours for light soil.
 - Select 4 hours for heavy soil.

4. IF YOU WISH TO DELAY THE START OF CLEANING (if not, skip to #5):

- Press STOP TIME pad.
- Press ▲ pad to select the time of day you wish the oven to turn off.
 - Press CLOCK pad and time of day will reappear in display.
 - Press STOP TIME pad to recall the time you set.



then



5. When the oven turns on:

- The OVEN ON indicator will light.
- LOCK indicator will light when oven heats to 400°.
- Internal lock will engage. Door cannot be unlocked and opened when LOCK indicator is lit.



← LIGHT TURNS ON WHEN OVEN REACHES 400°F.

6. About one hour after the clean cycle ends, the LOCK indicator will turn off. The oven door can be unlocked and opened.

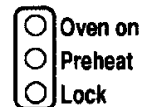

TO CANCEL CLEAN CYCLE:

- Press CANCEL pad.
- If LOCK indicator is NOT lit, unlock and open oven door.

If LOCK indicator is lit, allow oven to cool about one hour then unlock and open oven door.

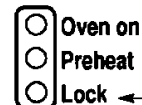

← WHEN LIGHT TURNS OFF, UNLOCK AND OPEN DOOR.



CAUTION

- Do not attempt to service this appliance yourself unless directed to do so in this manual or the chart below. Refer all other servicing to a qualified servicer or call us at **1-800-688-1120**.
- Locate and mark circuit breaker or fuse. Never replace a blown fuse or reset a circuit breaker until you know what caused the problem. Always replace a blown fuse with one of the correct amperage, do not use a substitute.
- Always disconnect power to unit **before** any servicing by tripping circuit breaker to the OFF position or by removing the fuse.

TROUBLESHOOTING CHART

PROBLEM	POSSIBLE CAUSES	SUGGESTED CORRECTIONS
Oven burner fails to light or oven does not operate.	<ol style="list-style-type: none"> 1. Power supply not connected. 2. Power failure. 3. Oven control lock-out feature is activated. 	<ol style="list-style-type: none"> 1. Connect power, check circuit breaker or fuse box. 2. Oven will not operate during a power failure or if disconnected from power. See page 7. 3. See page 6 to deactivate this feature.
Popping sound heard when burner goes out.	This is a normal sound that occurs with some types of gas when a hot burner is turned off. The popping sound is not a safety hazard and will not damage the appliance.	
Clock and/or oven light does not work.	<ol style="list-style-type: none"> 1. Power supply not connected. 2. Bulb may be loose or burned out. 3. Malfunctioning switch. 4. Malfunctioning clock or loose wiring. 	<ol style="list-style-type: none"> 1. Connect power supply, check circuit breaker or fuse box. 2. Tighten or replace light bulb. 3. Call serviceman to check. 4. Call serviceman to check.
Moisture condensation on oven window, if equipped	<ol style="list-style-type: none"> 1. It is normal for the window to fog during the first few minutes the oven is on. 2. Cloth saturated with water is used to clean the window. 	<ol style="list-style-type: none"> 1. Leave door ajar for one or two minutes to allow moisture to escape. 2. Use a damp cloth to clean window to prevent excess water from seeping between the panels of glass.
Oven temperature inaccurate. <ul style="list-style-type: none"> • food takes too long or cooks too fast • pale browning • food over-done on outside and under-done in center • over browning 	<ol style="list-style-type: none"> 1. Oven not preheated. 2. Incorrect rack position. 3. Incorrect use of aluminum foil. 4. Oven bottom incorrectly replaced. 5. Oven thermostat sensing device out of holding clip(s). 	<ol style="list-style-type: none"> 1. Preheat oven 10 to 15 minutes. 2. See page 17. 3. See page 8. 4. Replace oven bottom correctly. 5. Sensing device is located at the top rear of the oven cavity. Reinstall sensing device securely into clip(s). <p>See Problem Chart on page 12. See Baking Tips on page 11.</p>
Baking results differ from previous oven.	<ol style="list-style-type: none"> 1. Oven seems hotter or cooler than your previous oven. 	<ol style="list-style-type: none"> 1. See page 7 for instructions on adjusting the oven temperature. NOTE: Do not adjust temperature if only one or two recipes are in question. The problem may be the recipe rather than the oven.

NOTE: Oven temperatures may vary between the new and the old oven. As ovens age, the oven temperature often "drifts" and may become hotter or cooler. Also, newer ovens may operate differently from older ovens. You should expect some differences in baking results.

(Continued next page)

PROBLEM	POSSIBLE CAUSES	SUGGESTED CORRECTIONS
Baking results are not what you expected. <ul style="list-style-type: none"> • Uneven browning (too dark on top or bottom). • Underdone or overdone. • Browning is too dark or light. • Cake is not level. 	<ol style="list-style-type: none"> 1. Oven is too hot or too cool. 2. Selected BROIL rather than BAKE. 3. Food not positioned correctly in oven. 4. Used incorrect pan. 5. Used aluminum foil incorrectly. 6. Oven rack was crowded with pans. 7. Used unreliable recipe or did not follow recipe. 8. Oven vent was blocked. 9. Door is not correctly installed. 	<ol style="list-style-type: none"> 1. Select correct oven temperature. When baking, always preheat oven before adding food. See page 7 for instructions on adjusting the oven temperature. 2. Select the BAKE pad, not BROIL, for baking. 3. See rack placement on page 17. 4. Dark pans produce dark browning. Select shiny aluminum pans or reduce the oven temperature by 25°F. See page 11. 5. Never use foil to cover an oven rack. Place a small piece of foil on the rack below the rack holding the pan. See page 8. 6. Stagger pans on rack. Allow 1 to 2-inches between pans and oven walls. 7. Select recipes from reliable sources. Read and carefully follow instructions and do not substitute ingredients. 8. See page 15 for information on oven vent. 9. See page 16 for instructions on replacing door.
Food not broiling properly.	<ol style="list-style-type: none"> 1. Oven incorrectly set. 2. Used incorrect rack position. 3. Used aluminum foil incorrectly. 	<ol style="list-style-type: none"> 1. See page 13 for operating instructions. 2. See page 13 for information on broiling. 3. The broiler pan can be lined with foil; never line the broiler insert with foil.
Oven smokes excessively during broiling.	<ol style="list-style-type: none"> 1. Food placed too close to broil element. 2. Broiler insert covered with aluminum foil. 3. Meat is too fatty. 4. Marinade not completely drained before broiling. 5. Basted meat too early during broiling. 6. Used a soiled broiler pan. 	<ol style="list-style-type: none"> 1. Move broiler pan down one rack position. 2. Never cover insert with foil as this prevents fat from draining to pan below. 3. Trim excess fat before broiling. 4. Completely drain marinade from meat. 5. Baste meat during the last few minutes of cooking. 6. Always clean broiler pan and insert after use.
Oven will not self-clean.	<ol style="list-style-type: none"> 1. Self-clean feature was not properly set. 2. Oven set for a delayed clean. 3. Oven door not closed and/or locked. 	<ol style="list-style-type: none"> 1. Follow instructions on page 22. 2. Cancel program and reset clean cycle. 3. Close and lock oven door.
Oven door will not lock for self-clean.	<ol style="list-style-type: none"> 1. Self-clean was not properly set. 2. Oven door is not closed. 	<ol style="list-style-type: none"> 1. Follow instructions on page 22. 2. Be sure door is properly closed.
Oven door will not unlock after clean cycle or if accidentally locked during baking.	<ol style="list-style-type: none"> 1. Clean cycle ended less than one hour ago. 2. Oven hot enough to engage internal lock, if accidentally locked during baking. 	<ol style="list-style-type: none"> 1. Allow about 1 hour for oven to cool. Door can be unlocked when LOCK indicator is no longer displayed. See page 16. 2. Allow oven to cool until LOCK indicator no longer is displayed. To speed cooling, allow a fan to blow on oven door.
Moisture condensation on oven window.	<ol style="list-style-type: none"> 1. Window may fog when cooking food high in moisture. 2. Used a cloth saturated with water to clean window. 	<ol style="list-style-type: none"> 1. This condition is normal. 2. Wring excess water from cloth before cleaning.

PROBLEM	POSSIBLE CAUSES	SUGGESTED CORRECTIONS
Oven light does not turn on.	<ol style="list-style-type: none"> Oven light bulb is loose or burned out. Light switch in the OFF position. 	<ol style="list-style-type: none"> Check or replace bulb. See page 15 for instructions.
Strong odor or light smoke when oven is turned on.	<ol style="list-style-type: none"> "Burning off" of manufacturing oils or insulation. Food soil. 	<ol style="list-style-type: none"> This is normal for a new oven and will disappear after a few uses. A clean cycle will speed up the process. Turning on a ventilation fan will help remove the smoke and/or odor. Use self-clean feature.
<p>"F" plus a number appears in display.</p> 	<p>This is called a FAULT CODE. If a fault code appears in the display and beeps sound, press any pad except the CANCEL and ▲ or ▼ pads.</p> <p>If the fault code and beeps continue, disconnect power to the appliance. Wait a few minutes then reconnect power to the appliance. If the fault code and beeps still continue then call a factory authorized servicer or 1-800-688-1120.</p> <p>NOTE: If the oven is heavily soiled, excessive flare-ups may result in a fault code during a clean cycle. Press any pad except the CANCEL pad and the ▲ or ▼ pads and allow oven to cool for one hour then reset the clean cycle.</p>	

HOW TO REMOVE WALL OVEN FOR CLEANING AND SERVICING

Follow these procedures to remove appliance for cleaning or servicing:

1. Shut-off gas supply to appliance.
2. Disconnect electrical supply to appliance.
3. Disconnect gas supply tubing to appliance.
4. Remove the screws that secure the wall oven to the cabinet. Remove oven from cabinet.
5. Reverse procedure to reinstall. If gas line has been disconnected, check for gas leaks after reconnection. See Installation Instructions for gas leak test method.

NOTE: A qualified servicer should disconnect and reconnect the gas supply.

WARNING: Possible risks may result from abnormal usage, including excessive loading of the oven door and the risk of tip over, should the appliance not be reinstalled according to the installation instructions.

ELECTRICAL CONNECTION

Appliances which require electrical power are equipped with a three-prong grounding plug which must be plugged directly into a properly grounded three-hole 120 volt electrical outlet.

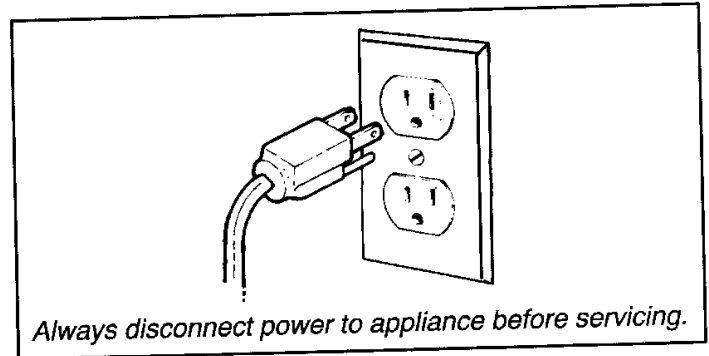

The three-prong grounding plug offers protection against shock hazards. **DO NOT CUT OR REMOVE THE THIRD GROUNDING PRONG FROM THE POWER CORD PLUG.**

If an ungrounded, two-hole or other type electrical outlet is encountered, **it is the personal responsibility of the appliance owner to have the outlet replaced with a properly grounded three-hole electrical outlet.**

WALL OVEN WARRANTY

FULL WARRANTY – Parts and Labor

For **one (1) year** from the date of original purchase date, any part which fails in normal home use will be repaired or replaced free of charge.

Canadian Residents: The above warranty only covers an appliance installed in Canada that has been certified or listed by appropriate test agencies for compliance to a National Standard of Canada unless the appliance was brought into Canada due to transfer of residence from the United States to Canada.

The specific warranty expressed above is the **only** warranty provided by the manufacturer. This warranty gives you specific legal rights, and you may also have other rights which vary from state to state.

WHAT IS NOT COVERED BY THESE WARRANTIES:

1. Conditions and damages resulting from any of the following:
 - a. Improper installation, delivery, or maintenance.
 - b. Any repair, modification, alteration or adjustment not authorized by the manufacturer or an authorized servicer.
 - c. Misuse, abuse, accidents or unreasonable use.
 - d. Incorrect electrical current, voltage or supply.
 - e. Improper setting of any control.
2. Warranties are void if the original serial numbers have been removed, altered, or cannot be readily determined.
3. Light bulbs.
4. Products purchased for commercial or industrial use.
5. The cost of service or service call to:
 - a. Correct installation errors.
 - b. Instruct the user on the proper use of the product.
 - c. Transport the appliance to a servicer.
6. Consequential or incidental damages sustained by any person as a result of any breach of these warranties.

Some states do not allow the exclusion or limitation of consequential or incidental damages, so the above exclusion may not apply to you.

HOW TO RECEIVE WARRANTY SERVICE:

1. For authorized service, contact the dealer from whom you purchased the appliance, or call Maytag Appliances Sales Company at: **1-800-688-1120**.
2. If you are not able to satisfactorily resolve the complaint with local response, call or write to:

Maytag Appliances Sales Company
Attn: CAIRSM Center
P. O. Box 2370
Cleveland, TN 37320-2370
1-800-688-1120
3. When requesting service, the following information will be needed:
 - a. Your name, address and telephone number.
 - b. Model and serial numbers (found on the data plate).
 - c. Name and address of dealer or servicer.
 - d. Proof of purchase date (sales receipt).
 - e. A clear description of the problem and service history.

BAKING

UTENSILS

1. Use the size utensil recommended in the recipe - **DO NOT** over or under fill the utensil. Always allow for expansion of foods or liquids.

HOW TO MEASURE PANS

Be sure your pans are the kind and size specified in the recipe. The size of some cookware is expressed in liquid measurement at its level full capacity.



Measure top inside of bakeware for length, width or diameter; measure perpendicular inside for depth.

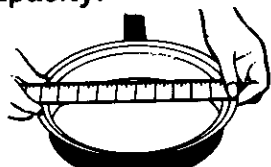

Sizes for skillets or frypans and griddles are stated as the top outside dimensions, exclusive of handles.

2. When using more than one utensil in oven, stagger them on the same rack or on two racks so that one is not directly below the other - make sure that the pans do not touch and are at least 1½ to 2 inches away from the oven walls and other pans.

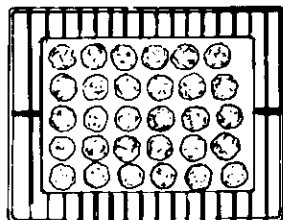
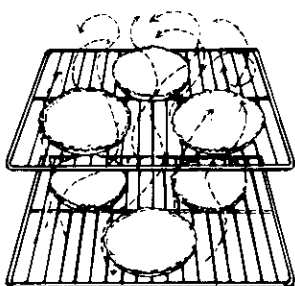

NUMBER OF PANS	RACK POSITION	PLACEMENT
1	2 or 3	center
2	2 or 3	opposite corners and at least 1½ to 2 inches apart.
3 - 4	2 or 3	opposite corner on two racks so that no pan is above or below the other.

3. Choose the correct utensil for what you are baking.
 - a. Shiny utensils - reflect heat the best and will produce a light even crust on cakes and pies.
 - b. Rough, dark or dull utensils - absorb heat and will produce a heavier, darker crust.
 - c. Glass utensils - absorb heat - you should turn your oven down 25° lower than the suggested temperature when using glass - they produce a heavier crust.

METHODS

Bake - To cook by dry indirect heat until food begins to brown or dry the exterior surface and interior has reached desired temperature.

Defrost or Thaw - To melt ice crystals from frozen foods by placing in a warm oven.

- a. Place in deep pan to catch run-off.
- b. Place in 150°F oven (most foods defrost approximately four times faster than at room temperature).
- c. Cook foods immediately after defrosting.
- d. **NEVER** refreeze.

Roast - To bake slowly, (at approximately 325°F) tender cuts of meats, in an uncovered pan.

- a. Calculate cooking time per pound.
- b. Set meat fat side up so it will baste itself.
- c. Place on lowest shelf.
- d. Insert meat thermometer to measure internal temperature.
- e. Allow meat to stand 15-20 minutes, before carving. The internal temperature will rise 5°F during standing time.

BAKING

RACK POSITIONS

It is important to cook foods on the proper rack.

- * Check rack position before any baking.
- * Always change racks while oven is cold.

HIGHEST 4th position
 MED. HI 3rd position
 MED. LOW 2nd position
 LOWEST 1st position

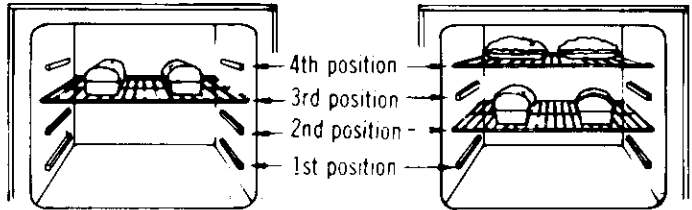

TYPE OF BAKING	RACK POSITION	REASON
Angel food	#1	Heat must be able to deflect to brown top.
Biscuits, cookies	2 or 3	Middle position allows for the most circulation and oven heating.
Cakes - casseroles	2 or 3	
Frozen pies	on cookie sheet #1	
Muffins and breads	2 or 3	Middle position allows most circulation and even heating.
Roasting	2 or 3	
Turkey or large roast	1	Allows easy access for basting.

ROASTING CHART

(OVEN TEMPERATURE 325°)

CUT	APPROX. WEIGHT	APPROX. MIN. PER LB.	INTERNAL MEAT TEMP.
Rib	6 to 8 pounds	23 - 25 27 - 30 32 - 35	140 Rare 160 Med. 170 Well
Boneless Rib	4 to 6 pounds	26 - 32 34 - 38 40 - 42	140 160 170
Rolled Rump (high quality)	4 to 6 pounds	25 - 30	150 - 170
Sirloin Tip	3½ to 4 pounds	35 - 40	140 - 170
Pork (fresh) Loin	3 to 5 pounds 5 - 7	30 - 35 35 - 40	170 170
Boneless Ham	2 - 5	30 - 45	170
Cook before eating ham	Under 10 pounds 10 - 15	20 - 30 17 - 20	155 - 160 155 - 160
Pre cooked ham		14 - 18	130
Shoulder picnic ham		25 - 35	170
Lamb Leg	5 to 8 pounds	30 - 35	170 - 180
Shoulder (whole)	3 to 5 pounds	30 - 35	170 - 180
Shoulder (boned)	3 to 5 pounds	40 - 45	170 - 180
Veal			
Leg. lamb shoulder	3 to 5 pounds 6 to 8 pounds	30 - 40 25 - 35	170 - 180 170 - 180
Poultry			
Chicken	3 to 5 pounds Over 5 pounds	30 - 40 35 - 40	185 - 190 185 - 190
Turkey	6 to 16 pounds 16 to 20 pounds Over 20 pounds	20 - 25 18 - 20 15 - 18	180 - 185 (in thigh) 180 - 185 180 - 185

BROILING

UTENSILS - Broiling pan and grid (included in oven) and deep metal pan with rack.

BROILING METHOD - Broiling is a method of cooking tender foods by direct heat under the burner. Generally, the distance between the meat and the burner and broiling time regulates degree of doneness.

Any steak for broiling should be at least $\frac{3}{4}$ inch thick. Thinner cuts will be done before they are brown and should be pan broiled instead.

Veal and Pork should not be broiled; veal because it is too lean; and pork because it requires long, slow cooking to be eaten safely.

Fish needs to be brushed in oil before broiling and placed skin side down in greased broiler pan.

Chicken needs to be less than 3 lbs. and occasionally basted with fat (will need a lower rack setting).

- a. Prepare meat - remove excess fat from meat and slash remaining fat being careful not to cut into meat - this will help excess fat to drain and keeps meat from curling.
- b. Position rack so that meat will be approximately 1 inch from the broiler. If you notice

an excessive amount of smoke, the rack has been placed too close to the broiler.

- c. Turn selector dial to broil, turn thermostat dial to broil - preheat is not necessary except for charcoal exterior with rare interior (steaks) preheat 5 - 10 minutes.
- d. Broiling should be done with the oven door open on electric ovens and door shut on gas ovens.
- e. Follow suggested times on broil chart - meat should be turned once about half way through broiling time.
- f. Check the doneness by cutting slit in meat near center for desired color.
- g. Remove broiler pan immediately after broiling so that dripping will not bake on and cause messy clean up.

EASY CLEANING

Allow to cool slightly then:

1. Remove broiler pan immediately after broiling.
2. Drain drippings.
3. Sprinkle with soap and cover bottom with wet paper towel - this will soften baked on foods and make clean up easy.

BROILING CHART

The times given in the chart should be used only as a guide. Increase or decrease broiling times to suit individual taste for doneness.

FOOD	THICKNESS & QUANTITY	DONENESS	SIDE 1	MIN. COOK TIME SIDE 2	TOTAL	
Bacon	8 slices	crisp	3	2	5	
		more crisp	5	3	8	
Beef Steaks	3/4"	rare	5-6	3-4	8-10	
	3/4"	medium	7-8	3-5	10-13	
		well	10-11	6-8	16-19	
Beef Steaks Frozen	1"	rare	6-7	4-5	10-12	
		medium	8-9	6-7	14-16	
		well	16-17	10-12	26-29	
Beef Steaks Fresh	1 1/2"	rare	8-9	6-8	14-17	
		medium	11-12	10-12	21-29	
		well	18-20	15-18	33-38	
Chicken Broiler Split & Quartered		180° internal	20 skin down	15 skin up	35	
Fish Fillets	1"		6-7	4-5	10-12	
			Frozen	1"	8-9	5-7
Hamburger Fresh	1/2"	rare	5-6	4-5	9-11	
		medium	6-7	4-5	10-12	
		well	9-10	5-6	14-16	
Hamburger Frozen	1/2"	medium	9-10	5-6	14-16	
Ham slice precooked	3/4"	150-160 internal	9-10	7-8	16-18	
Lamb Chops	3/4"	medium	6-8	3-5	9-13	
		Fresh	well	8-9	6-7	14-16
		Frozen	medium	8-9	6-7	14-16
Liver-Fresh	1/2" - 3/4"		4	3-4	7-8	
Lobster Fresh	7 oz.		shell up	shell down	13-15	
			7-8	6-7		
Frozen			14-16	11-12	25-28	

COOKING TERMS

BAKING POWDER - A leavening agent which makes foods rise when they are baked. It is a combination of baking soda, a dry acid or acid salt and starch or flour. The acid ingredient reacts with the baking soda to produce gas bubbles in the mixture. Double-acting baking powder produces gas bubbles twice: first during mixing and second during baking.

BAKING SODA - An essential ingredient of baking powder, may be used alone as a leavening agent in mixtures containing an acid ingredient such as buttermilk or in combination with baking powder. Mixtures containing baking soda should be baked as soon as mixed, since the soda starts to react as soon as it comes in contact with the liquid.

BARBECUE - To roast or broil food on a rack or spit over coals, or under a heat unit. The food is usually brushed with a highly seasoned sauce during the last of the cooking time.

BATTER - A mixture of fairly thin consistency, made of flour, liquid and other ingredients.

BEAT - To make a mixture smooth with rapid, regular motion using a wire whisk, spoon, hand beater or mixer. When using a spoon, the mixture should be lifted up and over with each stroke.

BLEND - To mix thoroughly two or more ingredients; or to prepare food in blender until pureed, chopped, etc., as desired.

BREAD - To coat with bread crumbs, cracker crumbs or cornmeal. Food may first be floured, then dipped in beaten egg or other liquid to help crumbs to adhere.

BROIL - To cook food by direct heat on a rack or spit.

BRUSH WITH - To use a pastry brush to spread food lightly with liquid such as salad oil, melted fat, milk, heavy cream or beaten egg.

CHOP - To cut food into small pieces with a knife, blender or food processor.

COAT - To sprinkle food with, or dip it into, flour, sauce, etc., until covered.

CUBE -

1. To cut food into small cubes (about ½ inch).
2. To cut surface of meat in checkered pattern to increase tenderness by breaking tough meat fibers.

CUT IN - To distribute solid fat in flour or flour mixture by using pastry blender or two knives scissor-fashion until flour-coated fat particles are of desired size.

DICE - To cut food into very small pieces (about 1/4 inch).

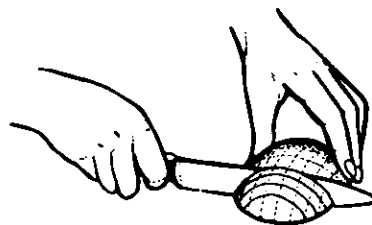

DICING AN ONION - Cut onion in half lengthwise, with cut side down, cut onion crosswise in 1/4 inch thick slices.

Hold onion firmly and give quarter turn; cut in 1/4 inch pieces. Repeat with other onion half.

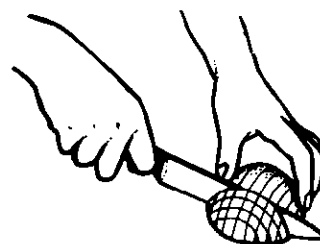

TERMS

DRAW - To remove entrails from, and clean, poultry or game. Drawn fish are whole fish that have been cleaned (eviscerated) but not boned.

DOT - To scatter bits, as of butter or margarine, over surface of food.

DREDGE - To cover or coat food, as with flour, cornmeal, etc.

DRESS - To mix salad or other food with dressing or sauce.

DRIPPINGS - Fat and juice given off by meat or poultry as it cooks.

FLAME - To ignite warmed alcoholic beverage poured over food. Also known as flambe.

FLOUR - 1. *All-purpose*. Made from a variety of wheats, it produces good results for a wide variety of baked goods. *Whole-wheat flour* is milled from the entire wheat kernel while *rye flour* is milled from the rye kernel. *Cake flour* is milled especially for cakes and other light baked products. For best results always use the flour called for in the recipe. In recipes calling for all-purpose and whole wheat or rye, a certain proportion of all-purpose to the other flour is needed for best results; so don't substitute flour. 2. To coat lightly with flour.

FLUTE - To make decorative indentations.

FOLD IN - To combine delicate ingredients such as whipped cream or beaten egg whites with other foods by using a gentle, circular motion to cut down into the mixture, slide across the bottom of the bowl to bring some of the mixture up and over the surface.

FONDUE - Most often a dish of hot melted cheese and wine, into which bread is dipped and then eaten. For meat fondues, at the table, cubes of meat are dipped in hot fat to cook,

then into a choice of sauces. Dessert fondues include chocolate or other sauces for dipping chunks of poundcake or fruit. The term also denotes a baked main dish made with cheese, milk and bread.

GELATIN - Available as unflavored and fruit-flavored. They are not interchangeable.

GLACE - 1. Glazed, as with a frosting. 2. Frozen.

Glaze. 1. To coat with a glossy mixture. 2. Concentrated stock used to add flavor.

GRATE - To rub food on a grater (or chop in blender or food processor) to produce fine, medium or coarse particles.

GRATIN - A French term defining a brown crust formed by baking or broiling bread crumbs, cheese, butter or a mixture on top of a casserole or other dish.

GREASE - To rub surface of dish or pan with fat, to keep food from sticking.

GARNISH - To add a decorative touch to food, as with parsley, croutons or prepared vegetables.

GRILL - To cook food on a rack by direct heat; also the appliance or utensil used for this type of cooking.

GRIND - To reduce to particles in food grinder, blender or food processor.

KNEAD - To work a food mixture (usually dough) with a press-fold motion.

LUKEWARM - At a temperature of about 95°F. Lukewarm food feels neither warm nor cold when in contact with inside of the wrist.

MARbled - Term used to describe meat with visible fat running through the lean.

TERMS

MARGARINE - Comes in several forms. Regular margarine with 80 percent fat is interchangeable with butter in recipes.

MARINADE - A seasoned liquid, in which food is soaked to enhance flavor.

MARINATE - To soak in a marinade.

MEAT TENDERIZER - Papain from natural tenderizers such as papaya is used to soften meat tissue. It is usually sprinkled on the meat before meat is cooked.

MERINGUE - Mixture of stiffly beaten egg whites and sugar. Also the cooked soft mixture on desserts or the cooked "hard" mixture as a dessert shell.

MINCE - To cut into very small pieces, using knife, food grinder or blender, or food processor.

PEEL - To remove outer covering of foods by trimming away with knife or vegetable peeler, or by pulling off.

POT-ROAST - To cook large pieces of meat or poultry by braising; also certain meat cuts.

PREHEAT - To heat oven to desired temperature before putting food into bake.

PUNCH-DOWN - To deflate a risen yeast dough by pushing it down with the fist.

PUREE - 1. A thick mixture made from a pureed vegetable base. 2. To press food through a fine sieve or food mill, or to blend in blender or food processor to a smooth, thick mixture.

PIT - To remove seed from whole fruit.

SCORE - 1. To cut shallow slits in surface of food to increase tenderness or to prevent fat covering from curling. 2. To decorate.

SHRED - To cut food into slivers or slender pieces, using a knife or shredder.

SHUCK - To remove meat of oysters, clams, etc. from their shells or to remove the husk from corn.

SKIM - To remove fat or scum from surface of food.

TOSS - To mix foods lightly with a lifting motion, using two forks or spoons.

TRUSS - To secure poultry with string or skewers, to hold its shape while cooking.

VINEGAR - An acid liquid used for flavoring and preserving. Among the types: Cider vinegar, made from apple juice, has a mellow fruit flavor; distilled white vinegar, usually made from grain alcohol; herb vinegars flavored with herbs; and red or white wine vinegars which also may be flavored with garlic.

WHIP - To beat rapidly with mixer, wire whisk or hand beater, to incorporate air and increase volume.

YEAST - Micro-organisms that produce carbon dioxide and alcohol from carbohydrates to cause baked goods to rise, fruits to ferment, etc.

EQUIVALENT MEASURES

Dash	2 to 3 drops or less than 1/8 teaspoon
1 tablespoon	3 teaspoons
1/4 cup	4 tablespoons
1/3 cup	5 tablespoons plus 1 teaspoon
1/2 cup	8 tablespoons
1 cup	16 tablespoons
1 pint	2 cups
1 quart	4 cups
1 gallon	4 quarts
1 peck	8 quarts
1 bushel	4 pecks
1 pound	16 ounces

BAKING PAN EQUIVALENTS

4 - CUP BAKING DISH:

- 9 inch pie plate
- 9 x 1 1/4 inch layer cake pan
- 7 3/8 x 3 3/8 x 2 1/4 inch loaf pan

6 - CUP BAKING DISH:

- 8 or 9 x 1 1/2 inch layer cake pan
- 10 inch pie plate
- 8 1/2 x 3 1/8 x 2 2/8 inch loaf pan

8 - CUP BAKING DISH:

- 8 x 8 x 2 inch square pan
- 11 x 7 x 1 1/2 inch baking pan
- 9 x 5 x 3 inch loaf pan

10 - CUP BAKING DISH:



- 9 x 9 x 2 inch square pan
- 11 3/4 x 7 1/2 x 1 3/4 inch baking pan
- 15 x 10 x 1 inch jelly roll pan

12 - CUP BAKING DISH AND OVER:

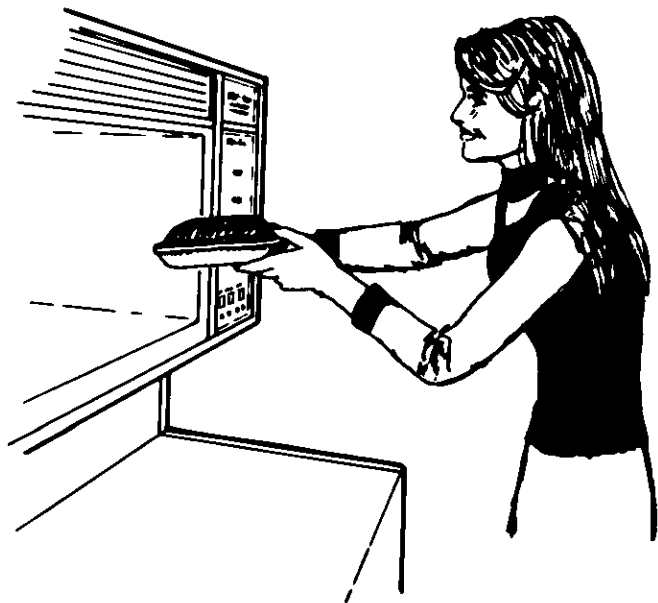
- 13 1/2 x 8 1/2 x 2 inch glass baking pan - 12 cups
- 13 x 8 x 2 inch metal baking pan - 15 cups
- 14 x 10 1/2 x 2 1/2 inch roasting pan - 19 cups

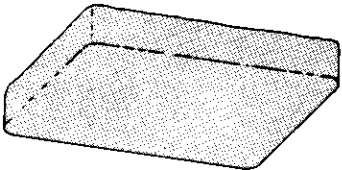
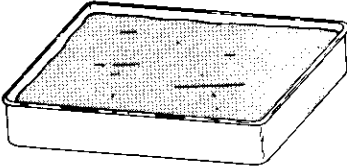

CAUSE & CORRECTION

PROBLEM	CAUSE	CORRECTION
BROWNING: Uneven bottom browning	1. Dented or warped pan. 2. Oven not preheated. 3. Range not level.	1. Use even bottomed pan. 2. Preheat to desired temp. before adding food. 3. Adjust leg levelers (see Use and Care).
Too brown on bottom 	1. Improper rack placement. 2. Oven door has been opened too often. 3. Oven not preheated. 4. Pans touching walls or other pans. 5. Warped, dark or dull finished pan (include glass).	1. Check for correct rack position before starting while oven is cold. 2. Open door only after food has been baked for shortest recommended baking time. 3. Preheat to desired temp. before adding foods. 4. Pans should not be closer than 1½ to 2 inches from each other or oven walls. 5. Use even bottomed, shiny pans for light browning.
Too brown on top. 	1. Oven doors open too often. 2. Overmeasuring. (fats-sugars-liquids). 3. Oven temp. too low. 4. Pan size too large.	1. Open door only after food has been baked for shortest recommended baking time. 2. Use standard measuring cups. 3. Double check recipe for correct oven temperature. 4. Use pan size recommended in recipe.
Crack on top.	1. Oven temperature too high. 2. Overmeasuring.	1. Double check recipe for correct oven temperature. 2. Use standard measuring cups.
Crumbly or dry. 	1. Oven temp. too high. 2. Over baking. 3. Over measuring.	1. Double check recipe for correct oven temp. - excess heat dries food. 2. Check foods after shortest baking time. 3. Use standard measuring cups.

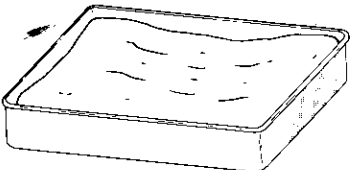
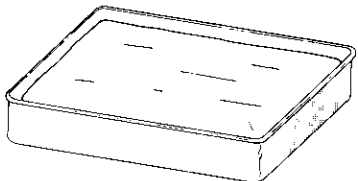
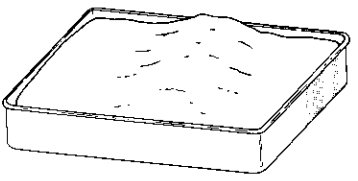
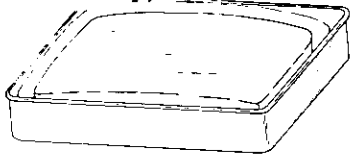
PROBLEM	CAUSE	CORRECTION
<p data-bbox="133 163 227 199">Fallen</p> 	<ol data-bbox="527 163 1003 640" style="list-style-type: none"> 1. Oven door opened too soon. 2. Oven temperature too low. 3. Old or too little baking powder. 4. Too much batter or too little pan. 5. Too much or too little liquid. 6. Under baked. 	<ol data-bbox="1003 163 1484 682" style="list-style-type: none"> 1. Check food only after the shortest recommended baking time. 2. Check recipe for correct oven temperature. 3. Use standard measuring utensils. 4. Use correct pan size. 5. Use standard measuring utensils. 6. Check food after shortest recommended baking time.
<p data-bbox="133 693 194 728">Flat</p> 	<ol data-bbox="527 693 1003 1176" style="list-style-type: none"> 1. Improper rack placement. 2. Old or too little baking powder. 3. Oven temperature too high or too low. 4. Pan too large for amount of batter. 5. Too much or too little liquid. 	<ol data-bbox="1003 693 1484 1207" style="list-style-type: none"> 1. Check rack position, before starting and while oven is still cold. 2. Use standard measuring utensil. 3. Check recipe for correct oven temp. and correct type of utensil (glass utensils) require lower temperature. 4. Use recommended baking utensil. 5. Use standard measuring utensil.
<p data-bbox="133 1218 511 1253">Mound or peaked center</p> 	<ol data-bbox="527 1218 1003 1575" style="list-style-type: none"> 1. Baking time too long. 2. Oven temperature too high. 3. Pan too large or too small. 4. Pans touching walls or other pans. 5. Too little liquid. 	<ol data-bbox="1003 1218 1484 1606" style="list-style-type: none"> 1. Check food after shortest recommended baking time. 2. Check recipe for correct oven temperature. 3. Use recommended baking utensil. 4. Pans should not be closer than 1½ to 2 inches. 5. Use standard measuring utensils.
<p data-bbox="133 1617 462 1690">Shrinkage (more than necessary).</p> 	<ol data-bbox="527 1617 1003 1848" style="list-style-type: none"> 1. Baking time too long. 2. Oven temperature too high. 3. Pans touching walls or other pans. 	<ol data-bbox="1003 1617 1484 1848" style="list-style-type: none"> 1. Check food after shortest recommended baking time. 2. Check recipe for correct oven temperature. 3. Pans should not be closer than 1½ to 2 inches.

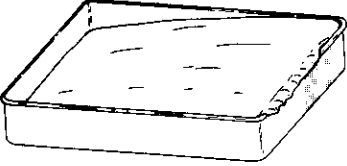
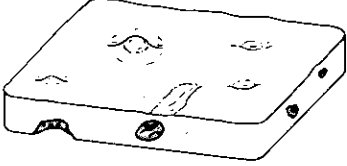
PROBLEM	CAUSE	CORRECTION
<p data-bbox="147 163 326 201">Uneven top</p> 	<ol data-bbox="553 163 1015 590" style="list-style-type: none"> 1. Pans touching walls or other pans. 2. Oven temperature too low. 3. Range not level. 4. Too much liquid. 5. Underbaking. 6. Undermixing. 	<ol data-bbox="1034 163 1495 590" style="list-style-type: none"> 1. Pans should not be closer than 1½ to 2 inches. 2. Check recipe for correct oven temperature 3. Adjust leg levelers (consult Use and Care Manual). 4. Use standard measuring utensils. 5. Check food after shortest recommended baking time. 6. Check recipe.
<p data-bbox="147 609 472 680">Uneven texture holes and tunnels.</p> 	<ol data-bbox="553 609 1015 1073" style="list-style-type: none"> 1. Baking time too short. 2. Improper rack placement. 3. Not baking immediately after mixing. 4. Oven temperature too high. 5. Too much baking powder. 6. Undermixing. 	<ol data-bbox="1034 609 1495 1108" style="list-style-type: none"> 1. Check foods after shortest recommended baking time. 2. Check rack position before starting and while oven is cold. 3. Always bake immediately. 4. Check recipe for correct oven temperature. 5. Use standard measuring utensils. 6. Use standard measuring utensils.

SERVICING

BEFORE YOU CALL A SERVICE TECHNICIAN CHECK THE FOLLOWING

SOME OR NONE OF YOUR RANGE OPERATES:

- _____ Is your range plug disconnected from the electrical outlet?
- _____ Are your house fuses blown?
- _____ Is your circuit breaker tripped?
- _____ Is the range plug loose or improperly plugged?

ELEMENT WON'T HEAT: (SURFACE UNITS ONLY)

- _____ Are your elements properly in place?
- _____ Are element prongs bent or dirty?

BAKED GOODS NOT TURNING OUT:

- _____ Are your racks properly in place and in correct position for what you are baking?
- _____ Is your range level? (Check leg levelers).
- _____ Are you using the proper pan? Is it bright, not soiled or dark colored?
- _____ Have you used foil during cooking or to line your oven?
- _____ Are you using standard measuring utensils?

OVEN WILL NOT OPERATE:

- _____ Did you turn the selector and thermostat switches to correct positions?
- _____ Clocks - are knobs in correct positions? See section on clocks and timers.

OVEN LIGHT WILL NOT WORK:

- _____ Is your bulb burned out?
- _____ Is your bulb loose?

NEED SERVICE? WHEN YOUR RANGE REQUIRES SERVICE OR REPLACEMENT PARTS, CONTACT YOUR DEALER OR AUTHORIZED SERVICE AGENCY. CONSULT THE YELLOW PAGES IN YOUR TELEPHONE DIRECTORY UNDER "RANGES" FOR THE SERVICE NEAREST YOU.

BE SURE TO INCLUDE: NAME, ADDRESS, PHONE, MODEL NUMBER, SERIAL NUMBER, AND COMPLAINT. SEE WARRANTY SHEET INCLUDED WITH THIS MANUAL FOR MANUFACTURERS ADDRESS.