

FOR FUTURE ASSISTANCE

Congratulations on the purchase of your new dishwasher! It is designed to handle virtually every dish you need to do. For best results, we suggest reading this guide to help you properly operate and maintain the appliance.

Please record your model and serial numbers in the spaces provided below. These numbers can be found in the upper left corner of the tub opening. They are needed for any correspondence or service calls concerning your dishwasher.

Model Number

Serial Number

▲ WARNING - Check with the installer to make sure the appliance has been properly grounded to avoid possible electrical shock. Be sure you read the **IMPORTANT PERSONAL SAFETY INSTRUCTIONS** before you start to use this dishwasher.

In addition, keep your sales slip or cancelled check should any warranty service be required. Proof of original date of purchase is needed.

In our continuing effort to improve the quality of our dishwashers, it may be necessary to make changes to the appearance without revising this guide.

IMPORTANT PERSONAL SAFETY INSTRUCTIONS

Products with a  label have been listed with Underwriter's Laboratories, Inc. – those with a CSA tag have been listed with Canadian Standards Association. Nevertheless, as with any other equipment using electricity and moving parts, there is a potential hazard.

▲ WARNING – When using your dishwasher, follow basic precautions, including the following:

1. Read all instructions before using the dishwasher.
2. Use the dishwasher only for its intended function.
3. Disconnect electrical power to dishwasher before attempting to service.
4. To avoid electrical shock hazard, the sides and back must be enclosed and the front panels must be attached before electrical power is applied to the dishwasher. Refer to the installation instructions for proper grounding procedures.
5. Connect to a properly rated, protected and sized power supply circuit to avoid electrical overload.
6. Children should never be permitted to operate, or play in, with, or around this dishwasher.
7. To reduce the risk of injury when loading items to be washed, sharp or pointed items should be located with the handles up. Also, load sharp items so they are not likely to damage the door seal.
8. Be careful not to touch the heating element on the bottom of the tub during or at the completion of a cycle. It may be hot.
9. Use only detergents and rinse additives designed for an automatic dishwasher. Never use soap, laundry detergent, or hand washing detergent in your dishwasher. Keep these products out of reach of children.
10. Do not sit, stand on or abuse the door or dish racks of the dishwasher.
11. Under certain conditions, hydrogen gas may be produced in a hot water system that has not been used for two weeks or more. **Hydrogen gas is explosive.** If the hot water system has not been used for such a period, turn on all hot water faucets and let the water flow from each for several minutes. This will release any accumulated hydrogen gas. As the gas is flammable, do not smoke or use an open flame during this process.
12. Do not wash plastic items unless marked "dishwasher safe" or the equivalent. For plastic items not so marked, check the manufacturer's recommendations.
13. Do not tamper with controls.
14. Always remove the door to the washing compartment when removing an old dishwasher from service or discarding it.

SAVE THESE INSTRUCTIONS

OPERATING STEPS

QUICK TIPS

1. Use Hot Water

to dissolve & activate detergent, dissolve greasy food soils and improve drying.

2. Use a Rinse Aid

regularly to improve drying results and reduce spotting and filming.

3. Use the Proper Detergent Amount

for best soil removal, good drying results and prevention of filming, etching, and spotting.

4. Load Properly

to ensure soiled surfaces get adequate wash action. (See page 3).

5. Select the Proper Cycle/Options

based on the amount of food soil on the load. (See page 4).

1. HOT WATER

For best results, the incoming water temperature should be 120-140°F. Check the water temperature by turning on the hot water faucet nearest the dishwasher and letting it run into a glass in the sink. Place a candy thermometer in the glass and check the temperature once it has stopped rising. If it is below 120°F have a qualified person raise the water heater setting.

Helpful Hints:

- If the outside temperature is unusually low, or if your water travels a long distance from the water heater to the dishwasher, you may need to increase your home's water heater setting and/or select water heating options on your dishwasher.
- If you have not used hot water for awhile, the water in the pipes will be cold. Turn on the hot water faucet at the sink and allow it to run until the water is hot. Start the dishwasher.
- If you've recently done laundry or run hot water for showers, your water heater may need time to recover before operating the dishwasher.

2. RINSE AID

Rinse aids come in solid or liquid form. When using a solid rinse aid, fasten it to the back right corner of the lower rack. Purchase more rinse aid when the material dissolves and the container is empty.

A liquid rinse aid dispenser (select models) automatically releases a measured amount of rinse aid into the final rinse portion of each cycle.

To fill the dispenser, turn the cap counterclockwise to open. Pour the rinse aid into the reservoir. Replace the cap and be sure it is securely in place before closing the dishwasher door. **Check the dispenser monthly and refill as needed.**

3. DETERGENT

Use a detergent designed specifically for use in an automatic dishwasher. Other types (laundry, hand soap, etc.) will cause over sudsing. Be sure to use fresh detergent and store it in a cool, dry place (not under the sink).

The amount of detergent to use depends on the water hardness (measured in grains per gallon-gpg) and the amount of soil on the dishes. Generally detergent amounts should be increased for harder water and heavier soil.

A basic guideline is one teaspoon (tsp.) of detergent for each grain of water hardness. Use a minimum of three teaspoons in soft water.* When using a concentrated detergent decrease the amount by half.

If the water hardness is 15 grains or harder, it is difficult to achieve good results with any dishwasher. The only solution is a mechanical water softener to improve water quality, detergent effectiveness, and to protect the dishwasher parts from damage that hard-water deposits may cause.

Detergent Usage Guide (powder or liquid)

CYCLES	SOFT WATER (0-3 grains)		MEDIUM WATER (4-9 grains)		HARD WATER (10-12 grains)	
	Main Cup	Open Cup	Main Cup	Open Cup	Main Cup	Open Cup
Super Scrub Pots & Pans Heavy Normal	3 tsp. minimum	3 tsp. minimum	4-9 tsp.	4-9 tsp.	10-12 tsp.	10-12 tsp.
Short	3 tsp. minimum	None	4-9 tsp.	None	10-12 tsp.	None
Rinse & Hold	Use no detergent		Use no detergent		Use no detergent	

* Your local water utility or state university extension service can tell you the degree of water hardness in your area.

4. **LOADING TIPS**

- Scrape off bones or large food particles. Remove excessive quantities of greasy/oily substances.
- Scrape or soak items with burnt on foods as they require more energy than the rest of the load to clean.
- If connected to a food waste disposer, make certain the disposer is empty before starting the dishwasher. This allows proper draining.
- Mustard, mayonnaise, vinegar, lemon and other acidic foods can cause rust or discoloration on stainless steel. Rinse these pieces as soon as possible.
- Starch from foods like potatoes, pasta, rice and oatmeal, require more energy to clean than the rest of the load.
- Place all items in the racks so they are separated and facing center.
- Wedge flat, lightweight items next to the silverware basket or along the sides and back of the racks.
- Load items so they do not rest over the wash tower.
- Avoid blocking the upper and lower spray arms by not allowing items to extend beyond the racks.
- Place glasses in any row of the racks for proper cleaning and rinsing. Do not load glasses over the tines.

Top Rack (Features vary slightly per model.)

This rack is designed to hold glasses, cups, small plates, bowls, cookware, etc. Bowls fit securely in the back right half of the top rack. Small plates or saucers should be loaded with soiled surfaces facing the center of the rack.

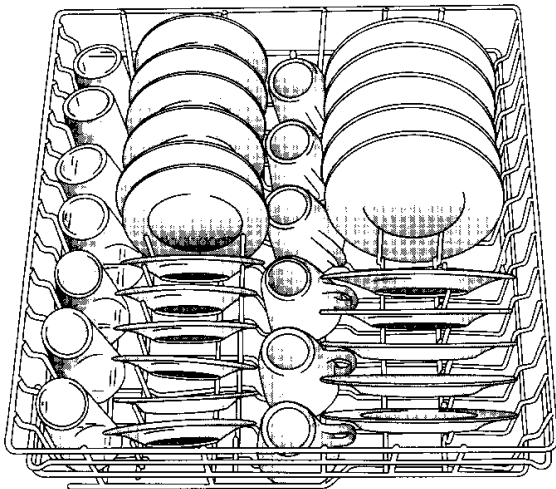

Bottom Rack (Features vary slightly per model.)

Large items may be placed in any convenient location in this rack. Keep soiled surfaces facing the center.

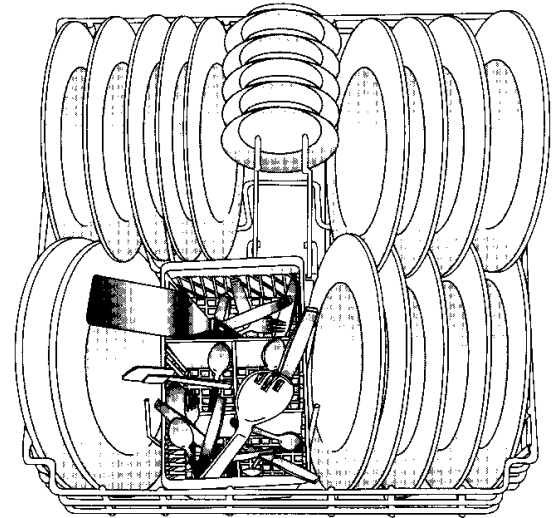

The back of this rack accommodates a row of dinner plates or two rows of smaller plates. Serving bowls, pots and pans also fit across the back of the rack.

Small plates, saucers or shallow bowls may be loaded in the elevated area behind the wash tower.

Folding tines located on the right side, provide loading flexibility for large-shaped items.

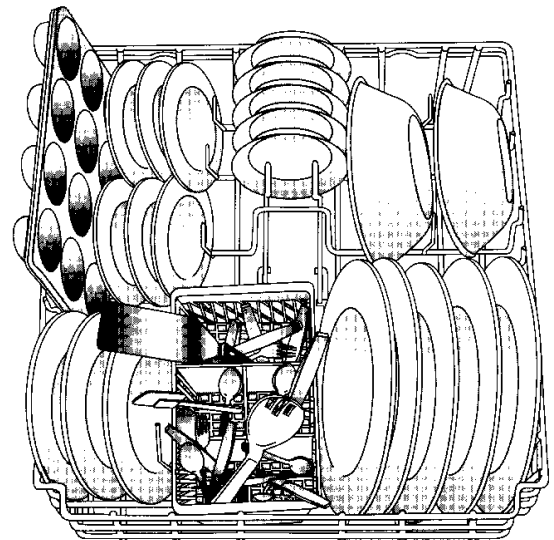

Removable Utensil Basket

Place flatware in the basket with some handles up and some down to prevent nesting. Always load sharp or pointed items with handles up.

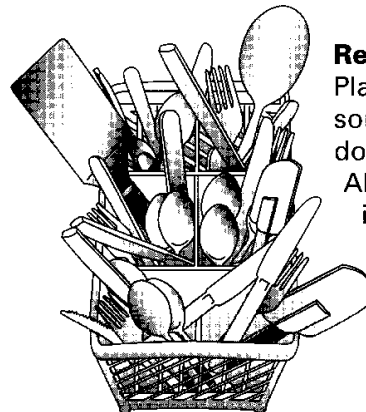

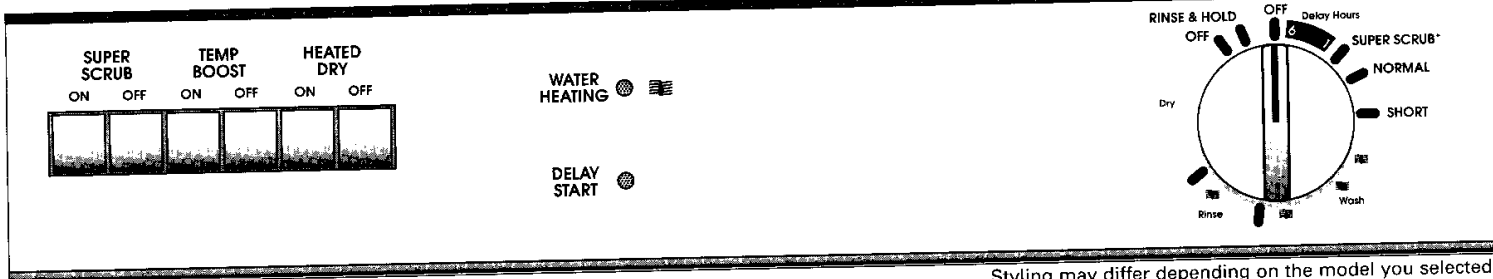

Styling may differ depending on the model you selected.

5. SELECT CYCLES/OPTIONS

Your dishwasher offers various cycles and options to adjust to specific load conditions. Please refer to the chart below for a description of each. **Select models feature cycles and options noted with a "*".**

Cycle	Sequence	Water Use
Super Scrub, Heavy, or Pots & Pans for heavily soiled dishes pots and pans	Prewash, 3 Rinses, Main Wash, 2 Rinses, Dry	10.5 gallons
Normal for normally soiled dishes	PreWash, 2 Rinses, Main Wash, 2 Rinses, Dry	9.0 gallons
Short for lightly soiled dishes	2 Rinses, Wash, 2 Rinses, Dry	7.5 gallons
Rinse & Hold rinses dishes waiting for a full load	Rinse, Off	1.5 gallons

Super Scrub On* provides water temperature checks throughout the cycle. **Super Scrub Off*** provides a shorter cycle with fewer water temperature checks. An indicator light comes on if water is being heated and the cycle is extended.

Temp Boost* helps ensure proper water temperature for activating detergent and dissolving greasy food soils.

Super Wash* provides a water temperature check in prewash.

Heated Dry On turns the heating element on to improve drying results. **Heated Dry Off** turns the element off to save energy. Towel drying may be needed with this option.

Delay Hours can be used to delay the start of the cycle for up to 6 hours. Turn the control knob to the desired number of delay hours and latch the door. The dishwasher will begin when the selected amount of time has elapsed.

Note: The dishwasher will only delay into the longest cycle (ie: Super Scrub or Pots & Pans). It will **not** delay into the Normal or Short cycles.

CARE AND CLEANING

Clean the control panel and front panels with a lightly dampened cloth. Dry thoroughly. Do not use abrasives or sharp objects on the panel. They can damage it.

The inside normally takes care of itself. Occasionally check the tub bottom for large food pieces which may have collected. Periodically clean the edge of the door liner and gasket if any food spills are noticed.

To remove any odor, try one of the following:

- Put baking soda in both cups. Select the normal cycle and let the water circulate for about 10 minutes. Unlatch the door and let it sit overnight. Then relatch the door and let the cycle finish.
- Select the Normal cycle and let the dishwasher fill with water. Then open the door and pour 1/4 cup of chlorine bleach into the bottom of the dishwasher. Latch the door and let it complete the cycle.
- Try a lemon scent detergent and/or rinse aid to help periodically freshen the dishwasher interior.
- Run the dishwasher more frequently. Use the Rinse & Hold cycle (if available) to remove any food soil that may cause an odor.

STORING DISHWASHER

If your dishwasher will be in storage or an unheated area exposed to freezing temperatures:

- Clean the dishwasher as explained in the Care and Cleaning section.
- Operate the drain portion twice to ensure most of the water is removed. Most dishwashers begin each cycle with a drain.
- Disconnect the electrical supply and prop open the door.

WHAT CAN AND CANNOT BE WASHED

Remember. It is the user's responsibility to determine if the item should be washed in a dishwasher.

Material	Usually Safe	Exceptions (not safe)	Special Instructions
Aluminum	Yes	Some colored anodized aluminum can fade.	If darkens or spots, remove by scouring with soap-filled steel wool pads.
Cast Iron	No	Iron will rust.	
China/ Stoneware	Yes	Antique, metal-trimmed, hand-painted or over-the-glaze patterns fade. Gold leaf will discolor.	If in doubt, check with the manufacturer. Or test, by washing one piece daily for several weeks.
Crystal	Yes	Antique, metal-trimmed or painted patterns fade.	Load securely to prevent movement. Check with manufacturer.
Nondishware items— such as electronic air cleaner filters, furnace filters, paint brushes, etc.	No		Do not wash in dishwasher. It may damage, discolor or stain the dishwasher.
Glass	Yes	Milk Glass may yellow.	
Pewter	No	Pewter tarnishes.	
Plastics	Yes		If it doesn't say DISHWASHER SAFE, test one piece before dishwashing an entire set.
Stainless Steel	Yes		Rinse if not washing immediately. Salty or acidic foods stain if left on.
Sterling Silver and Silver plate	Yes	Don't put in same silverware basket with stainless steel. Contact between metals can damage silver. Don't wash copper utensils in the same load. Silver may get a brown film.	Rinse if not washing immediately. Salty or acidic foods stain if left on. Check with the manufacturer.
Non-stick coatings	Yes		
Tin	No	Tin can rust.	
Wood	No	Wood can warp, crack or lose its finish.	

Q.

COMMON QUESTIONS AND ANSWERS

A.

Dishwasher Won't Run?	<ul style="list-style-type: none">• Be sure door is latched securely.• Be sure the water is turned on.• Check that the dial/pad is properly selected for a cycle.• Allow time for select models to drain/pause before filling.• Check your home's circuit breaker or fuse box.
Unusual Noise?	<ul style="list-style-type: none">• A water valve hiss during fill is normal.• Water circulation sounds are normal.• A ticking noise is a normal timer sound.• A thumping sound may be a wash arm bumping an item that is extending beyond the racks.• Chopping or grinding sounds may be heard during drain as the internal food disposer chops hard items like fruit seeds, nuts, etc.• Humming during drain is normal.• A snap noise is the detergent cup lid hitting the door liner when the dishwasher door is opened at the end of the cycle. This is normal.• Proper installation affects the noise level.
Dishes Don't Dry?	<ul style="list-style-type: none">• Check the rinse aid dispenser to see if it needs refilling.• Select the Drying Heat option.• Check incoming water temperature.• Load properly. Dishes shouldn't nest together. Avoid overloading.• Unload the bottom rack first. Water from dishes in the top rack may be spilling into the bottom rack.• Plastic and teflon items have a porous surface and tend to hold water. Towel drying may be required.• Glasses, cups, etc., with concave bottoms will hold water.
Unclean Dishes And Flatware?	<ul style="list-style-type: none">• Check incoming water temperature.• Run hot water at the sink before starting the dishwasher.• Select water heat (select models).• Check water hardness and adjust detergent amount accordingly.• Use fresh detergent stored in a cool dry place.• Select proper cycle for the soil level.• Load items so they do not block the wash arms or center tower.• Load the utensil basket with some handles up and some down to prevent nesting.• Do not place glasses over tines.
Detergent Left In Dispenser Cups?	<ul style="list-style-type: none">• Check that the cycle is completed.• Be sure dispenser is not blocked.• Use fresh detergent stored in a cool, dry place.
Stains Or Marks On Dishes Or Tub?	<ul style="list-style-type: none">• Aluminum utensils can leave marks when they rub against other things. Leave a slight space between items.• Iron deposits in the water can leave a yellow, brown or orange film on dishes. A filter may be needed or periodically use RoVer Rust Remover.*• Food soil stains normally require hotter water and more detergent to remove and prevent.
Dishes Chipped?	<ul style="list-style-type: none">• Rough handling can cause chipping. Load with care. Make sure glassware and china are secure and can't jar loose. Do not load glasses over tines. Make sure tall glasses and stemware will clear the top of the tub when you push the rack into the dishwasher.• Refer to the previous chart on "What Can and Cannot Be Washed".

Q. & A. CONTINUED

Spots And Film On Glasses And Flatware?

Spotting can be caused by all these things:

- Extremely hard water.
- Low inlet water temperature.
- Overloading the dishwasher.
- Improper loading.
- Old or damp detergent.
- Rinse aid dispenser empty.
- Too little detergent.

Due to the varying local water conditions and personal preferences, try different brands of detergent to find one that gives the best results for you.

To remove the spots and film from glassware:

1. Remove all metal utensils from the dishwasher.
2. DO NOT ADD DETERGENT.
3. Select the NORMAL WASH cycle.
4. Start the dishwasher and allow to run for approximately 20 minutes. The dishwasher will now be in the main wash.
5. Then open the door and pour 1/2 cup (125ml) of white vinegar into the bottom of the dishwasher.
6. Close the door and allow the dishwasher to complete the cycle. Try using a vinegar rinse twice a month. Consider a home water softener.

Cloudy Glassware?

If vinegar doesn't remove the cloudiness, it is "etching." The film is permanent.

To Prevent:

1. Use less detergent if you have soft water.
2. Avoid manually pre-rinsing the dishes.
3. The temperature of water entering the dishwasher should be 120° F — 140° F.

Dishwasher Won't Drain?

- If hooked up to a food waste disposer, be sure the knock-out is removed from the disposer inlet.
- Be sure the drain hose is elevated at least 32" so water cannot siphon back into the tub.
- Check for food obstruction in the drain or disposer.
- Check drain hose for a kink.
- Check your home's circuit breaker or fuse box.
- Check that the cycle is completed.

Suds In The Tub?

Sudsing detergents are not meant for dishwashers. **USE ONLY AUTOMATIC DISHWASHER DETERGENTS TO AVOID SUDSING.**

To remove suds from the tub:

1. Open the dishwasher door and sprinkle 1 cup of salt on top of the suds to help evaporate them.
2. Close and latch the dishwasher.
3. Turn the dial until a drain is reached or select the drain pad.
4. Repeat if necessary.

Dishwasher Leaks?

- Check that the dishwasher is level. (Refer to the Installation Instructions.)
- Suds can cause the dishwasher to overflow. Measure the detergent carefully and use only detergents designed for use in a dishwasher. Less detergent is needed in soft water. Try another brand if sudsing continues.
- To avoid rinse aid leaking from the dispenser, be sure the lid is securely attached. Wipe up any accidental spills.

Odor?

- Dishwashers will have a "new" smell when installed. This will decrease with time.
- Soiled dishes held too long. Use the Rinse & Hold, if available.
- Dishwasher not draining properly.
- A chemical odor is usually due to chlorine bleach in dishwashing detergents. You may want to try another brand.

* Brand names are trademarks of the respective manufacturer.