

Frigidaire

Factory Parts Catalog

Product No.	XGTI1845KF0	XGTI1845KR0
Series	R134a	R134a
Color	stainless (RH)	stainless (LH)
Volts	115	115
Wiring Diagram	241582401	241582401
Owner's Guide	242008000	242008000
Market	North America	North America
Energy Guide	242028516	242028516
Service Data Sheet	241588203	241588203
Installation Instructions	240568304	240568304

TOP-MOUNT REFRIGERATOR WITH ICE-MAKER

Model No.
XGTI1845K

Publication No.
5995551941
09/09/11
(EN/SERVICE/DCS)
390

DOOR

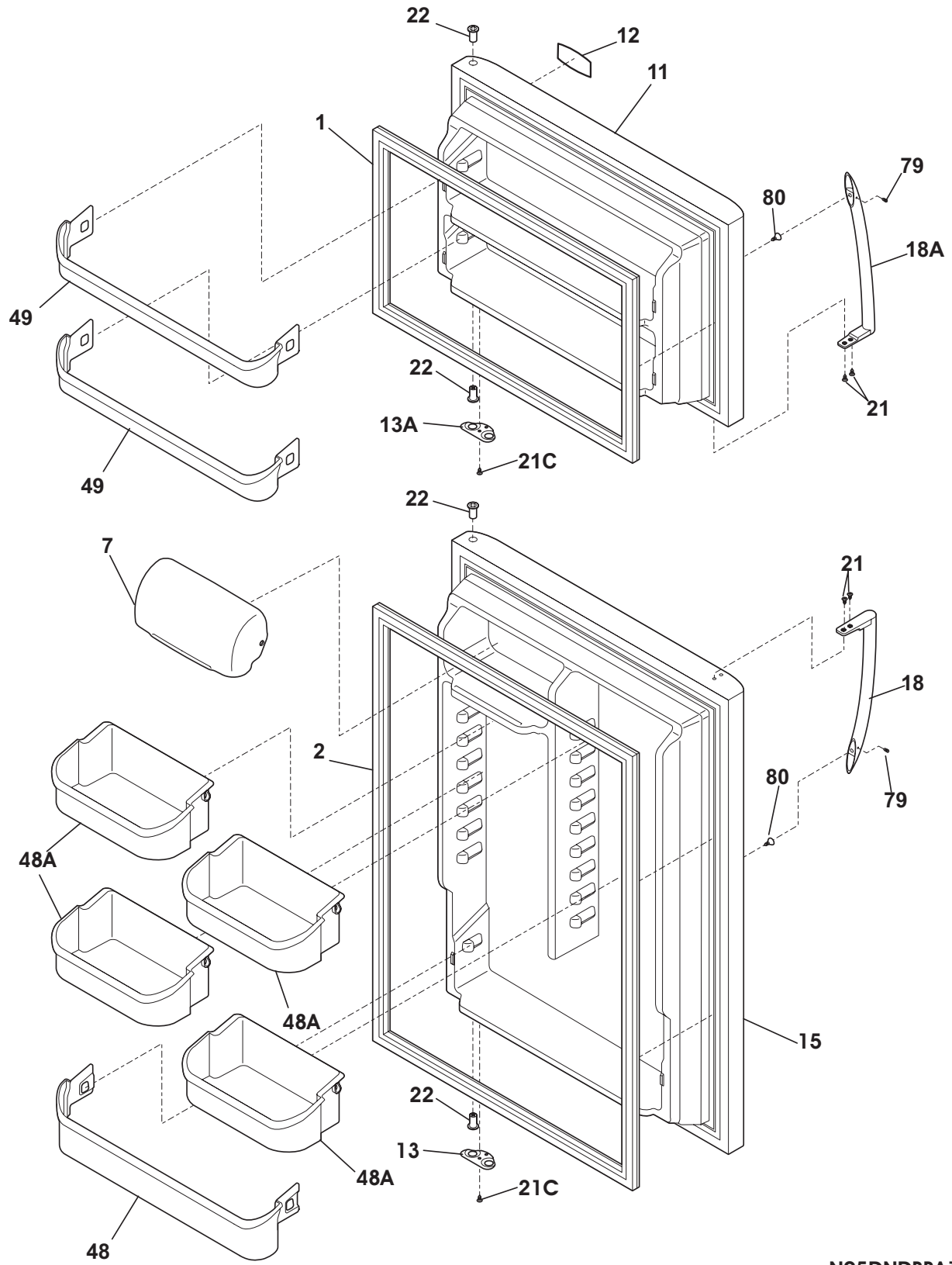

N05DNDDBA1

DOOR

Model Index: A XGTI1845K (XGTI1845KF0)
 B XGTI1845K (XGTI1845KR0)

POS. NO	PART NO.		DESCRIPTION
1 #	241872503	A B	Gasket-frzr door, white, magnetic
2 #	241872506	A B	Gasket-refr door, white, magnetic
7	240338313	A B	Door, dairy, clear
11	241623327	A -	Door-frzr, stainless, complete assy
11	241623328	- B	Door-frzr, stainless, complete assy
12	242015201	A B	Label-nameplate
13	240312405	A B	Door Stop, black, refr
13A	240312415	A B	Door Stop, black, frzr
15	241623439	A -	Door-refr, stainless, complete assy
15	241623440	- B	Door-refr, stainless, complete assy
18	241977502	A B	Handle-door, stainless, refr-LH/frzr-RH
18*	241601001	A B	Wrench, allen
18*	241701901	A B	Screw Driver
18A	241977501	A B	Handle-door, stainless, refr-RH/frzr-LH
21	240383406	A B	Screw, truss hd quad, #10-16 x .500, zinc
21C	218252201	A B	Screw, #8 truss hd, 10-32CA x 0.500
22	240527102	A B	Bearing-hinge, black
48	240338101	A B	Bin-door, pseudo, bottom
48A	240338201	A B	Bin-door, gallon, white
49	240495804	A B	Bin-door, pseudo, frzr
79	218755402	A B	Screw-set, 10-32 x 0.375
80	218755504	A B	Screw-shoulder, #10 AB, handle mounting

CABINET

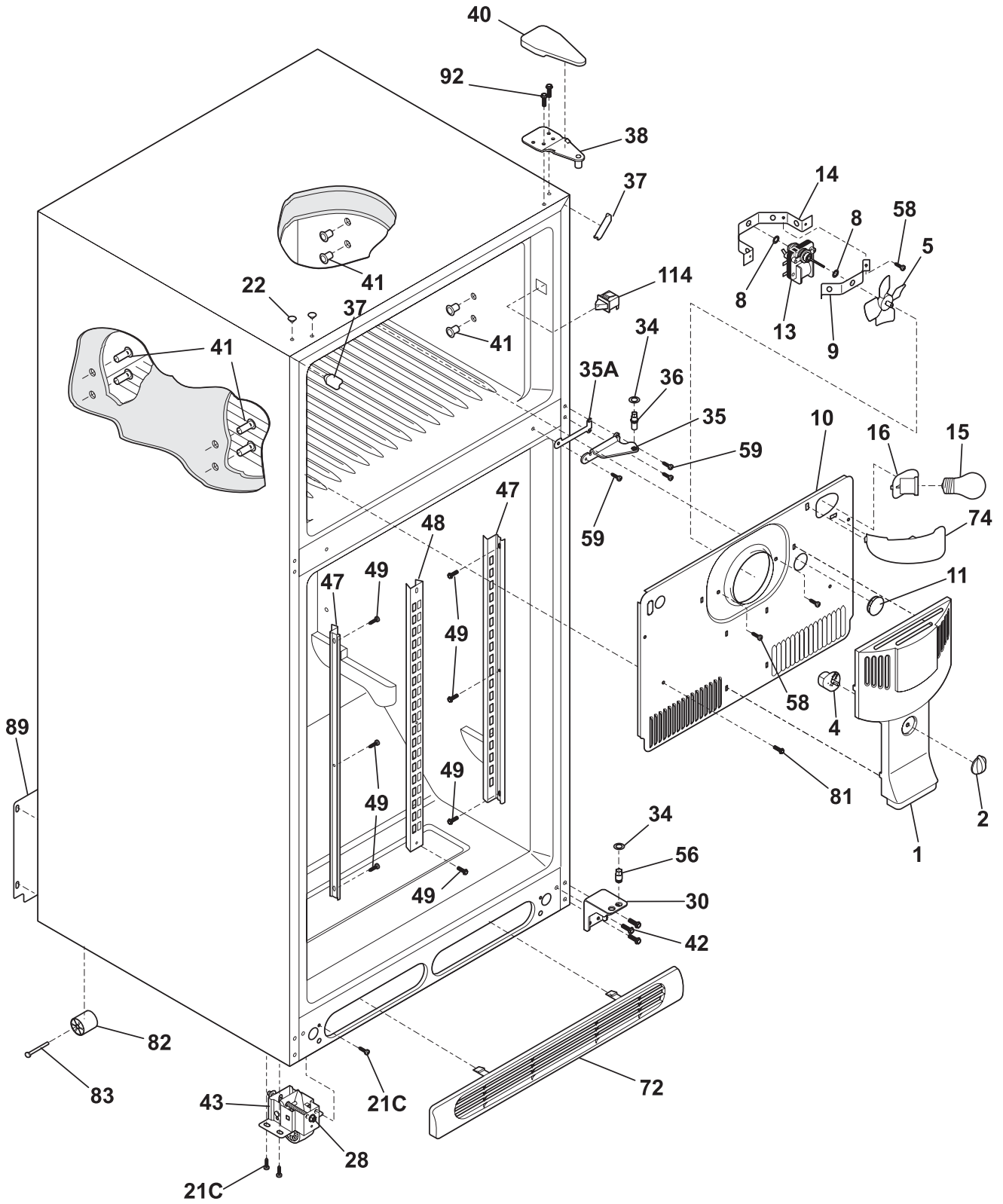

N05BAAAAC15

CABINET

Model Index: A XGT11845K (XGT11845KF0)
B XGT11845K (XGT11845KR0)

POS. NO	PART NO.		DESCRIPTION
1	241652301	A B	Cover-fan
2	240367001	A B	Knob-damper control
4	241523701	A B	Damper-fan cover
5 #	5308000010	A B	Fan Blade, red, evaporator fan
8	242014101	A B	Bushing-motor mtg, (2)
9	5303292396	A B	Bracket-motor mtg, front
10	241652213	A B	Cover-evap coil
10*	240568601	A B	Seal-coil cover
11	5303208309	A B	Plug-hole, factory test
13 #	241854501	A B	Motor-evap fan
13*	215474201	A B	Washer, "slinger", nylon, evap fan shaft
13*	218515401	A B	Clip
14	5303292397	A B	Bracket-motor mtg, rear
14*	240433204	A B	Screw, hex washer head, 8-18 x 5/16
15	241560701	A B	Light Bulb
16 #	241513901	A B	Socket-light
21C	218252201	A B	Screw, #8 truss hd, 10-32CA x 0.500
22	215774921	A B	Plug-button, gray, upr hinge holes
28	240335502	A B	Bolt-roller adj, hex washer head, 1/4-20 x 4.020, (2), special
30	240314003	A B	Bracket-lower hinge, black
34	240311303	A B	Washer, hinge, nylon, (2)
35	240313802	A B	Bracket-ctr hinge, white
35A	240336802	A B	Spacer-hinge, center
36	240516402	A B	Pin-center hinge
37	241611307	A B	Trim-cabinet corner, gray, (2)
40	240354407	A B	Cover-upper hinge, gray
41	5308009759	A B	Grommet, shelf mtg, 1.25", LH, (4)
42	240578902	A B	Screw, hex head, 1/4-20 x 5/8
43	240335006	A B	Roller Assy, front, (2)
47	218233301	A B	Channel-shelf mtg, side, (2)
48	5303292395	A B	Channel-shelf mtg, center
49	218362501	A B	Screw, hex washer head, 8-18AB x 1.250, spacer, (2)
56	240516502	A B	Pin-lower hinge
58	5304456287	A B	Screw, hex washer head, 8-15A x 0.500
59	240442708	A B	Screw-#10-32 X 3/4, white
72	241839413	A B	Grille/Kickplate, gray
74	240354302	A B	Shield-light, frzr
81	5304455650	A B	Screw, hex washer head, 8-15A x 0.625, low profile
82	5304418225	A B	Roller, compressor base, rear, (2)
83	5304455655	A B	Rivet, flat head, 1/4 OD x 1-3/4, roller pin
89	241733907	A B	Cover-access, with label
89*	241500304	A B	Screw, hex washer head, 8-18AB x 0.625
92	241710601	A B	Screw, hex washer hd, 1/4 x 7/8, hinge mtg
114	241554901	A B	Switch-light/lamp

SHELVES

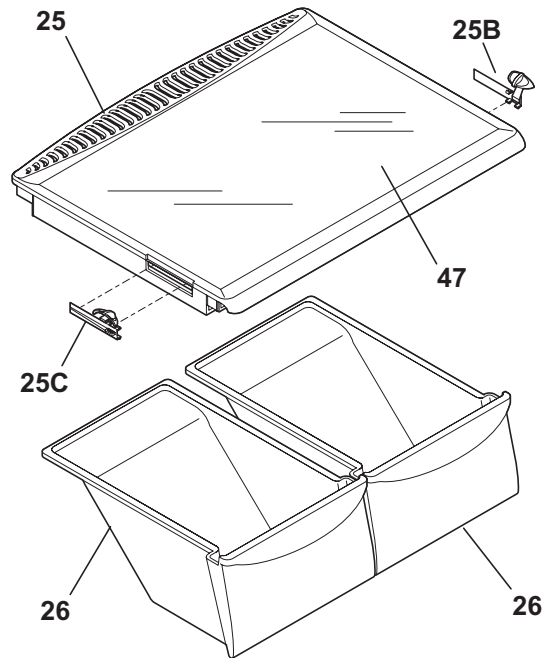
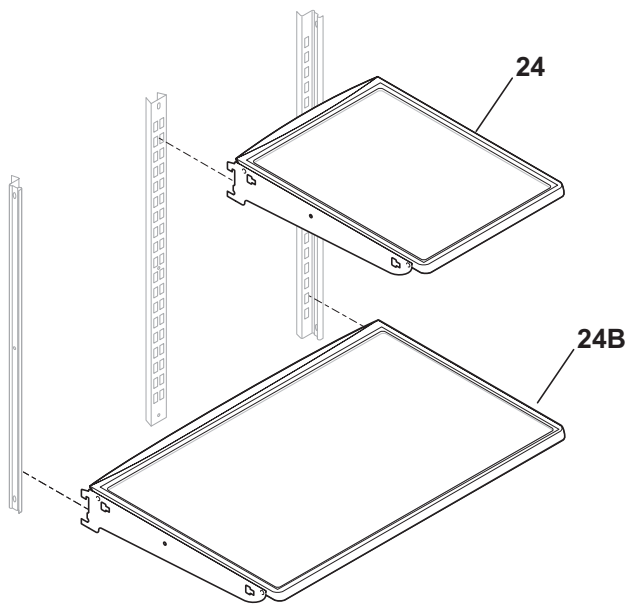
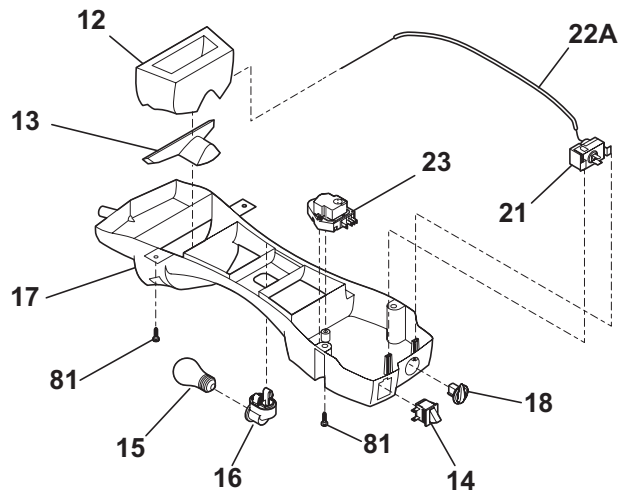
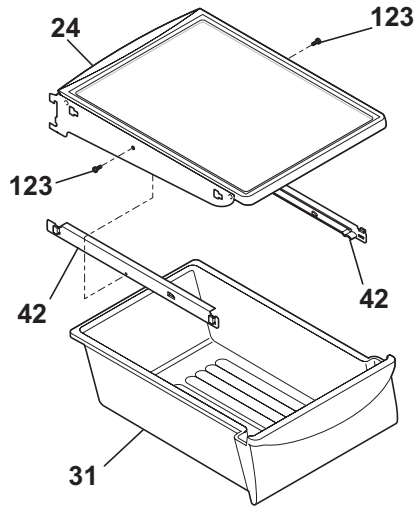
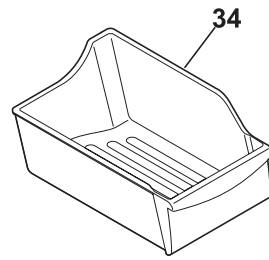
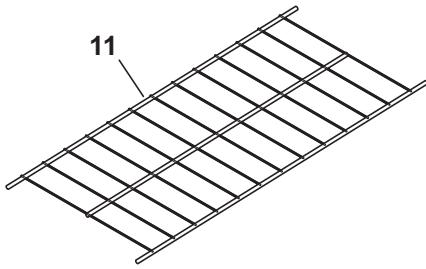

N05SACAFH16

SHELVES

Model Index: A XGTI1845K (XGTI1845KF0)
 B XGTI1845K (XGTI1845KR0)

POS. NO	PART NO.		DESCRIPTION
11	240358005	A B	Shelf, freezer, full-width, wire
12	241542001	A B	Diffuser, air, top
13	240362601	A B	Diffuser, air, bottom
14 #	241554901	A B	Switch-light/lamp
15	241555401	A B	Light Bulb
16	241559801	A B	Socket-light
17	240352702	A B	Control Box
17*	240568607	A B	Seal
17*	240570304	A B	Tape, aluminum, 3" wide
17*#	240388701	A B	Wiring Harness, control box
18	240360801	A B	Knob, temp control
21 #	5304421256	A B	Control, temperature
22A	240468201	A B	Tube, sensor sleeve, 31 inch, plastic, white
23 #	241809401	A B	Timer-defrost
23*	5304455649	A B	Screw, pan hd, 6-20 x 0.438
24	241616607	A B	Shelf-"Spill-Safe", cantilever, half width, fixed
24B	241712304	A B	Shelf-"Spill-Safe", cantilever fixe
25	240364787	A B	Cover-crisper pan
25B	241613501	A B	Control-humidity, RH
25C	241613502	A B	Control-humidity, LH
26	240337103	A B	Pan-crisper, clear, (2), no graphics
31	240530811	A B	Pan-meat, w/o graphics, clear
34	240385201	A B	Container, ice bin
42	240356501	A B	Track, meat pan hanger, RH
42	240365401	A B	Track, meat pan hanger, LH
47	240350608	A B	Insert-pan cover, 23.82" x 15.50", glass
81	5304455650	A B	Screw, hex washer head, 8-15A x 0.625, low profile
123	215005101	A B	Screw, hanger/rlr mtg, 8-10 x 7/16
*	242028516	A B	Energy Guide

SYSTEM

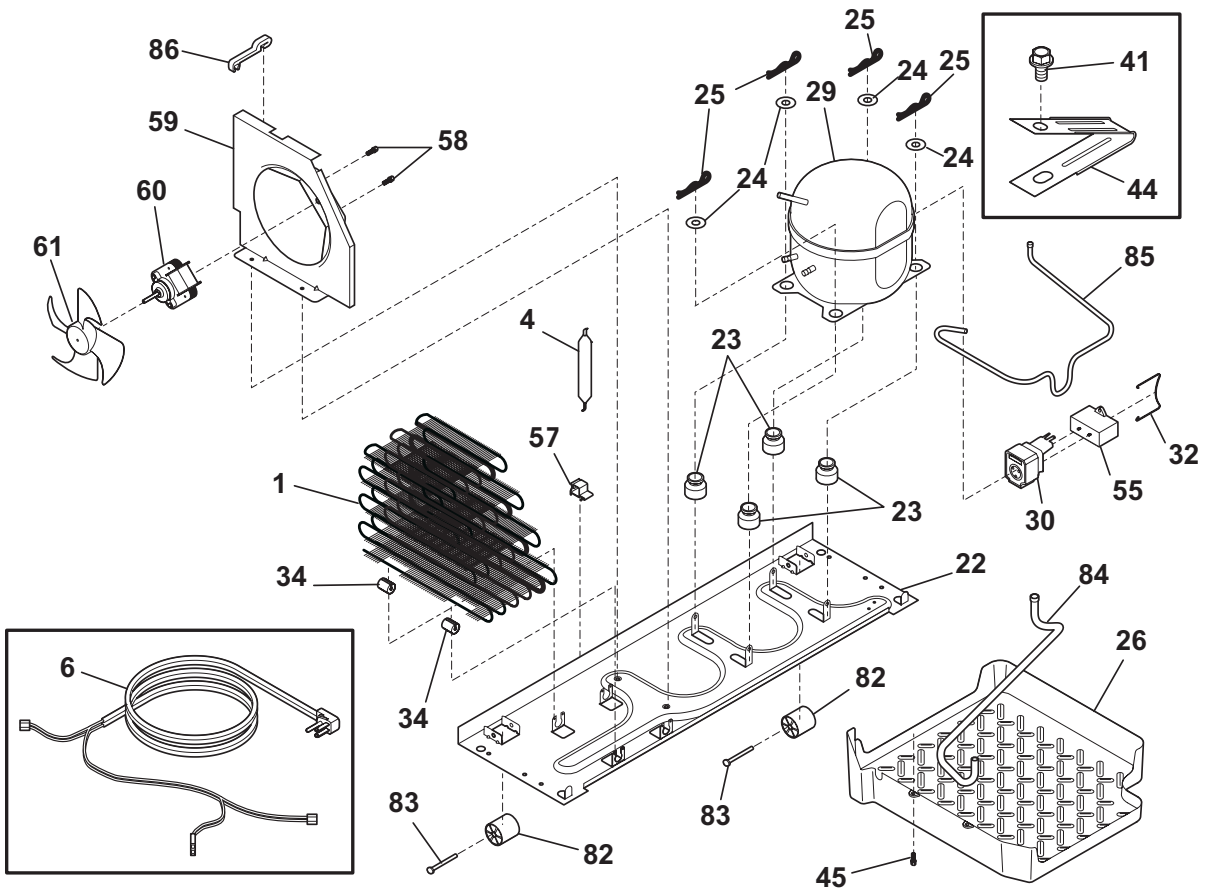
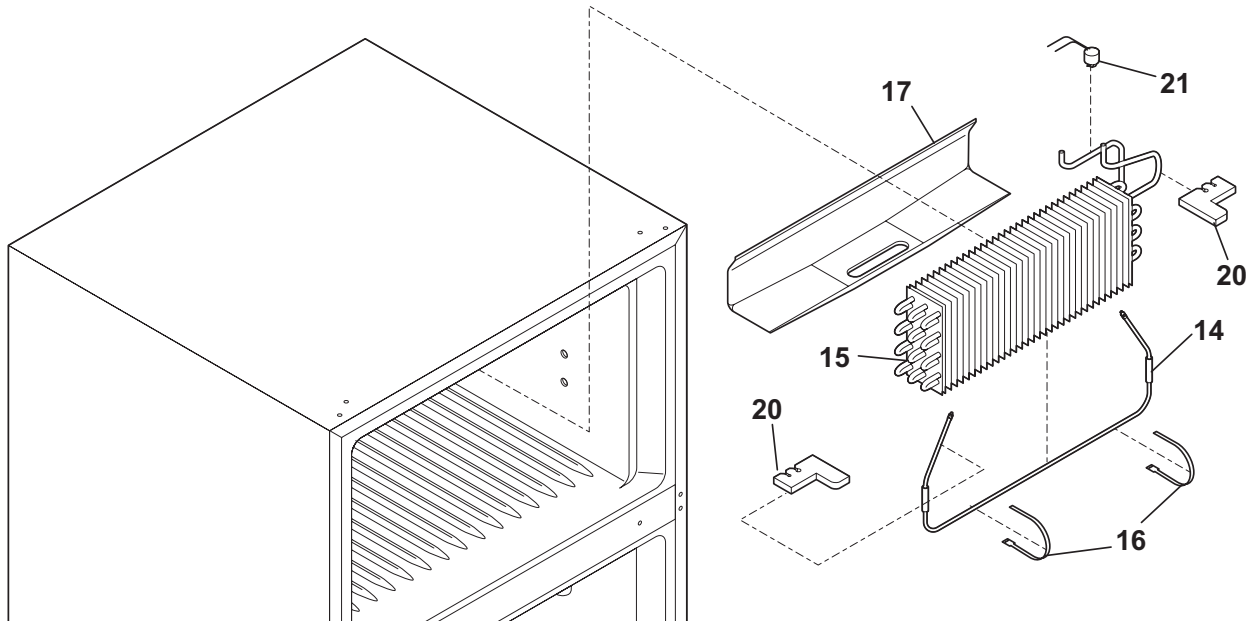

N05CAABAD5

SYSTEM

Model Index: A XGTI1845K (XGTI1845KF0)
 B XGTI1845K (XGTI1845KR0)

POS. NO	PART NO.		DESCRIPTION
1 #	241785402	A B	Condenser, dynamic
4	218944002	A B	Drier-filter, R134a System
6 #	241607001	A B	Harness-wiring, machine compt
6* #	240388701	A B	Wiring Harness, control box
14 #	240356221	A B	Heater-defrost
15 #	5303918274	A B	Evaporator Kit
16	5308000110	A B	Strap-evap/heater, aluminum, (2)
17	241801301	A B	Trough-drain
20	241551902	A B	Insulation Block
21 #	5303918202	A B	Thermostat-defrost, kit
22	241665606	A B	Base-compressor
22*	218252201	A B	Screw, #8 truss hd, 10-32CA x 0.500
23	218513300	A B	Grommet-compr mtg, (4)
24	241812301	A B	Washer-compr mtg
25	242037701	A B	Clip-compressor mtg
26	241683601	A B	Pan-defrost
29 #	5303918415	A B	Compressor Kit
30 #	241707720	A B	Starter-PTC
32	216649200	A B	Clip, controller
34	240405201	A B	Grommet, rubber, black, cond tube/wire
41	240433204	A B	Screw, hex washer head, 8-18 x 5/16
44	5304456288	A B	Clamp-wiring harness, strain relief, galv steel
45	241500304	A B	Screw, hex washer head, 8-18AB x 0.625
55	218909913	A B	Capacitor, run, 220 VAC, 15 microfarad
57	240542601	A B	Clip-wiring harness
58	240569201	A B	Screw, 8-18 x 0.500
59	241946104	A B	Shroud-cond fan
59*	240346701	A B	Tape-foam seal, shroud
59*	240359403	A B	Screw-fan shroud, (2)
60	241584301	A B	Motor-condenser fan
61	241639501	A B	Blade-condenser fan
82	5304418225	A B	Roller, compressor base, rear, (2)
83	5304455655	A B	Rivet, flat head, 1/4 OD x 1-3/4, roller pin
84	240500801	A B	Tube-drain, rubber, lower
85	242014601	A B	Tube-connector, suction
86	240409302	A B	Spacer-cond tube, black
*	240396801	A B	Clamp, tube/wiring, nylon, black/natural
*	5303918222	A B	Hot Tube Repair Kit, service
*	5303918263	A B	Heat Exchanger Kit, suction line

ICE MAKER

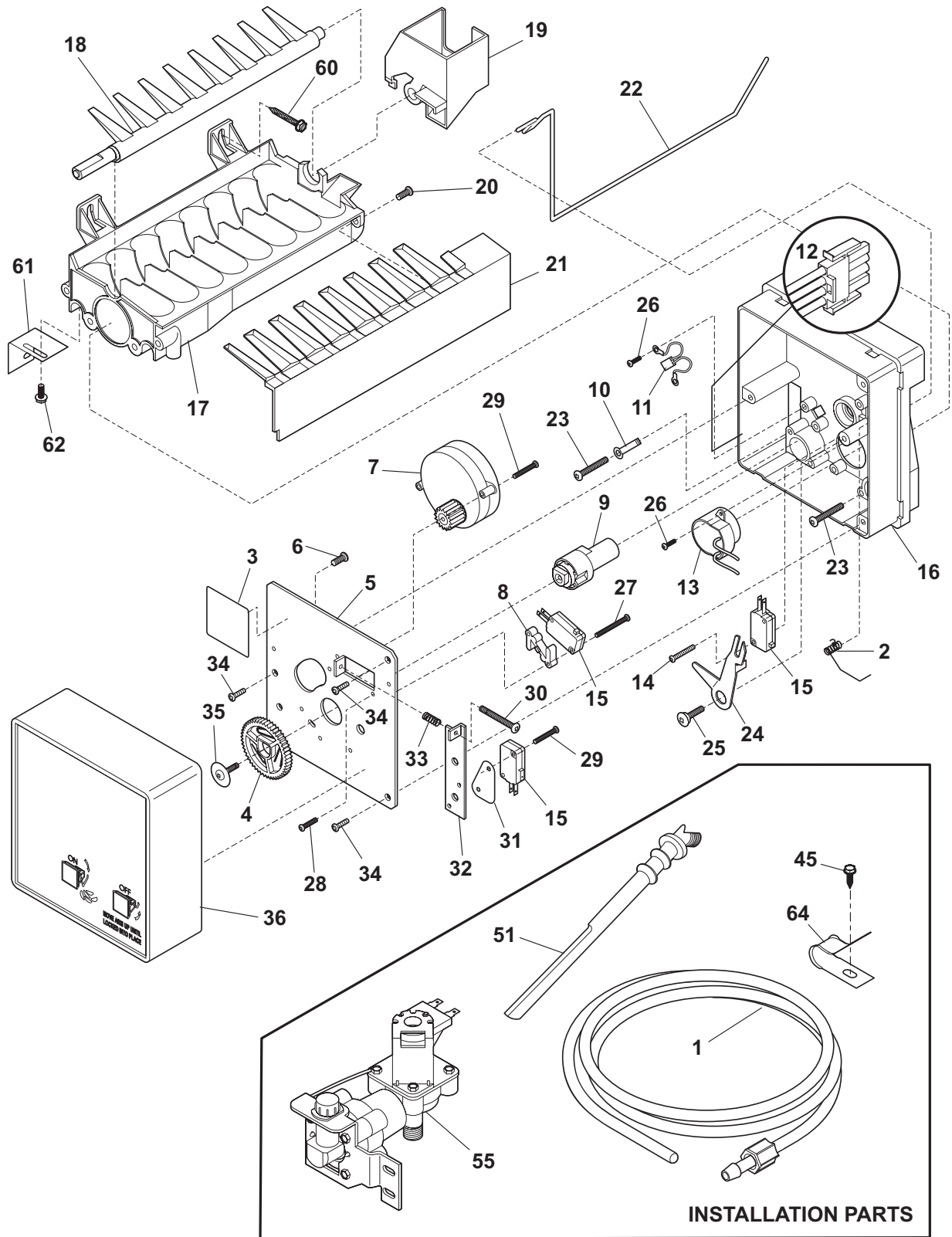

N0511151-1

ICE MAKER

Model Index: A XGTI1845K (XGTI1845KF0)
B XGTI1845K (XGTI1845KR0)

POS. NO	PART NO.		DESCRIPTION
1	218976921	A B	Tube-water inlet, valve to I.M.
1*	240561701	A B	Seal-water inlet, inlet valve, to ice maker
2	5304456650	A B	Spring-shutoff arm, ice maker
3	5304456657	A B	Nameplate
4	5304456658	A B	Gear
5	5304456659	A B	Plate-mounting
6	5304456691	A B	Screw, M 3x20 #3, valve plate
7 #	5304445222	A B	Motor-ice maker Svo
7*	5304445223	A B	Spring Beam
8	5304456661	A B	Spacer-hold switch
9	5304456662	A B	Cam
10	5304456689	A B	Washer, nylon
11 #	5304456663	A B	Thermal Cutoff, ice maker, complete assy
12 #	5304456875	A B	Harness-wiring, icemaker
13	5304456665	A B	Thermostat, ice maker
14	5304456666	A B	Screw, M 3x20 #2, (6)
15 #	5304456667	A B	Switch-micro, (3)
15*	5304456688	A B	Terminal
16	5304456668	A B	Support
17	5304456669	A B	Mold-ice maker, w/therm cut off
18	5304456670	A B	Ejector-ice
19	5304456671	A B	Bearing & Inlet, fill cup
20	5304456677	A B	Screw, 8-32 x 3/8
21	5304456672	A B	Ice Stripper
22	5304456673	A B	Shut-off Arm
23	5304456674	A B	Screw, M 4x25 #2, mold-to-support, (2)
24	5304456675	A B	Lever Arm
25	5304456676	A B	Screw, M 4x12.8 #2, lever arm/sprt
26	5304456680	A B	Screw, plask, 4-14 x 3/8
27	5304456677	A B	Screw, M 3x25 #3, hold switch mtg, (2)
28	5304456660	A B	Screw, M 4x6 #2
29	5304456678	A B	Screw, M 3x12 #3, (2)
30	5304456679	A B	Screw-timing adj, M 4x25 #3
31	5304456680	A B	Insulator
32	5304456681	A B	Plate-valve switch
33	5304456682	A B	Spring, timing adjust
34	5304456683	A B	Screw, M 4x12 #2, (3)
35	5304456684	A B	Screw
36	5304456685	A B	Cover-ice maker
36*	5304456690	A B	Label, ID plate
45	5304456650	A B	Screw, hex washer head, 8-15A x 0.625, low profile
51	241523501	A B	Tube-water, ice mold fill, extension
55 #	241803701	A B	Valve-water, single solenoid, 60 Hz, 105/120 V
60	218362501	A B	Screw, hex washer head, 8-18AB x 1.250, spacer, (2)
61	5304456686	A B	Bracket-leveling, ice maker
62	5304456687	A B	Screw-IM brkt mtg, pan hd phillips, 8-32T x 0.375
64	5304455846	A B	Clamp, .31 ID, steel, water tube
*	241642501	A B	Ice Maker, radius cube, 115 V, Svce
*	241642601	A B	Harness-wiring Svo
*	5304456692	A B	Washer
*	5304456693	A B	Nut, M 3.5
*	5304456737	A B	Washer

WIRING SCHEMATIC

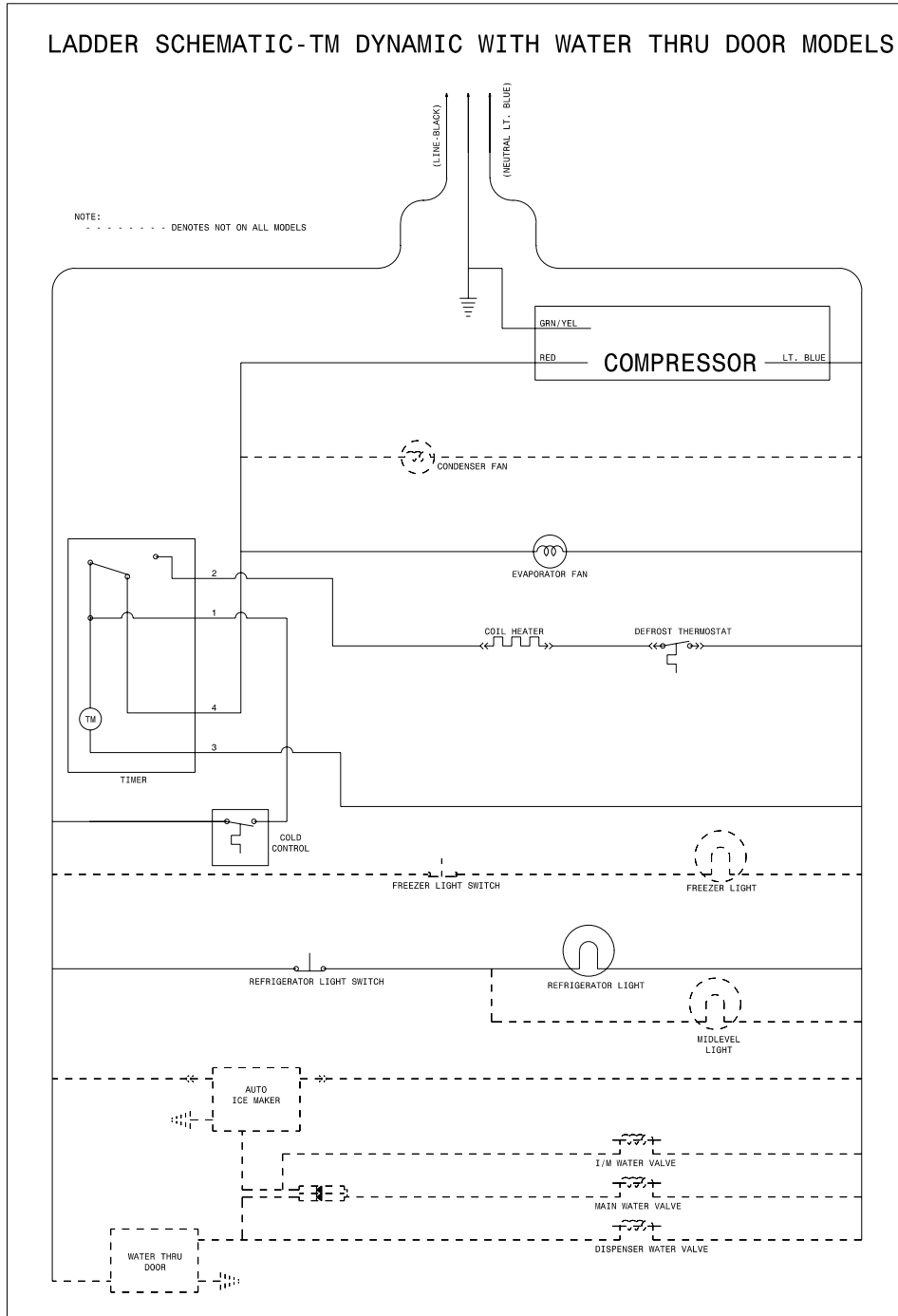

WIRING DIAGRAM

